

SAFETY GUARDING SOLUTIONS

STAY AWAY - STAY SAFE



BELT CONVEYOR **GUARDING**

Proven Safety Guarding Solutions

OUR VALUE PROPOSITION



At Belt Conveyor Guarding, we specialize in the design and manufacturing of high-quality safety guarding solutions for commercial and industrial applications. For 35 years, we have been committed to helping companies across North America enhance workplace safety. Our products are designed to be ergonomic, user-friendly, and compliant with all relevant standards.

Ensuring compliance with safety standards is essential, but we believe that modern and innovative guarding should offer more than just compliance. It should add value by making equipment maintenance quick and efficient. That's why our guards provide a range of benefits, including, but not limited to:

- › Guards are designed for your specific needs
- › Guards are easily handled by just one person
- › Guards can be removed and installed in seconds (not hours), reducing costly downtime

Unsure where to begin or which guard is right for your specific needs? Our team of experienced professionals is here to answer all your technical questions and recommend the best solution for your application.

By partnering with Belt Conveyor Guarding on your guarding project, you'll be joining hundreds of clients already saving thousands of dollars each year by reducing downtime and preventing worker injuries. Contact us today to start saving!

OUR CORE VALUES

Walk The Talk: We do what we say and always make it right

No Half-Ass: We accept nothing short of perfect

Every Level of Service Matters: We surpass customers' expectations every step of the way

We Are Different: Simply because we innovate, and we lead



BELT CONVEYOR GUARDING

Proven Safety Guarding Solutions

Toll Free: 1-866-300-6668 | Fax: 1-705-725-8835

safety@conveyorguarding.com

www.conveyorguarding.com



GENERAL GUARDING DATA	EXPECT EXCEPTIONAL SERVICE	4	
	ROI AND MAINTENANCE	5	
	ERGONOMICS OUTLOOK	6	
	GUARD SEATS	6	
	SAFETY GAUGE	7	
	MESH SIZES AND TYPES	8	
RISK ASSESSMENTS	SAFETY GUARDING ASSESSMENT	9	
	RISK MATRIX & REPORTS	10	
	ASSESSMENTS	11/12	
GUARDING FASTENERS	SMART WEDGE CLAMP	13	
	LOCKING WEDGE CLAMP	14	
MULTI-PURPOSE GUARDING	FLAT GUARDS	15	
	FLAT GUARD MOUNTING OPTIONS	16	
	MODULAR BARRIER GUARDS	18	
	ROLLING SAFETY GATES	19	
	COUPLING GUARDS	20	
DRIVE GUARDS	PUMP GUARDS	21	
	V-BELT GUARDS	22	
ROTATING SHAFT GUARDS	BOX GUARDS	23	
	FLANGE BEARING GUARDS	24	
RETURN IDLER BASKETS	RETURN IDLER BASKETS - CHAIN MOUNT	25	
	RETURN IDLER BASKETS - RIGID MOUNT	26	
RETURN IDLER GUARDS	RETURN IDLER GUARDS	27	
	RETURN IDLER BELLY GUARD	28	
	RETURN IDLER SIDE GUARDS	29	
	HANDRAILS & GUARDRAILS	30	
SPECIALTY GUARDS	LADDER GUARDS	31	
	GUARD HANGERS	32	
	CABLE TIE CADDIES	32	
ACCESSORIES	HANDLES	33	
	SERVICE/INSPECTION DOORS	34	
	SIGNS AND DECALS	35	
	PUMP AND V-BELT GUARD DATA SELECTION	36	
	CHART PUMP GUARD DATA SHEET - UPRIGHT	37	
DATA SHEETS	PUMP GUARD DATA SHEET- INVERTED	38	
	V-BELT GUARD DATA SHEET - UPRIGHT	39	
	V-BELT GUARD DATA SHEET- INVERTED	40	
	V-BELT GUARD DATA SHEET - PIVOT	41	
	COUPLING GUARD DATA SHEET	42	
	PILLOW BLOCK BEARING GUARD DATA SHEET	43	
	FLANGE BEARING GUARD DATA SHEET	44	
	TAIL BARRIER DATA SHEET	45	
	GENERAL GUARDING DATA	PARTS IDENTIFICATION	46
		ASSEMBLY AND INSTALLATION	46
COMPLIANT GUARDING SYSTEMS		47	



EXPECT EXCEPTIONAL SERVICE

WHEN YOU REQUEST A QUOTATION, YOU WILL RECEIVE THE FOLLOWING:

- An itemized list of the required guards, along with corresponding quotes
- Maps, if applicable, to illustrate where the quoted guards will go
- Installation guidelines will be provided once an order has been placed.

WHEN YOU PLACE AN ORDER, WE ARE PLEASED TO OFFER THE FOLLOWING SERVICES:

- If our Technicians have already been to your site, we will have the majority of the information needed to design your guards. If not, we can schedule a site visit.
- Guards are shipped as complete systems, with each system securely skidded and labeled according to the area it is designated to protect, eliminating the need for on-site sorting of components.
- Each individual guarding system and its components are each labeled for ease of identification and installation.
- Most large components of the guarding system are labeled with their weight to ensure worker safety during installation and maintenance.
- Installation drawings are included with each skid for reference and are also provided electronically for your records.
- You will be notified by email when your order ships and will be provided with the freight details, tracking information, and the estimated arrival date.
- We will track your shipment and provide updates as needed. Proof of delivery will be confirmed with you once we receive notification from the carrier.
- We offer installation support as needed to ensure a smooth installation process and to help make your guarding project a success. Your satisfaction is our priority.

BENEFITS OF OUR GUARDS INCLUDE:

- Reducing & eliminating workplace injuries
- Increasing productivity
- Decreasing fines, citations, and costly shutdowns
- Extending the life of your equipment
- Ensuring compliance with relevant standards and regulations

ANYTHING WE CAN DO TO HELP – WE WILL.

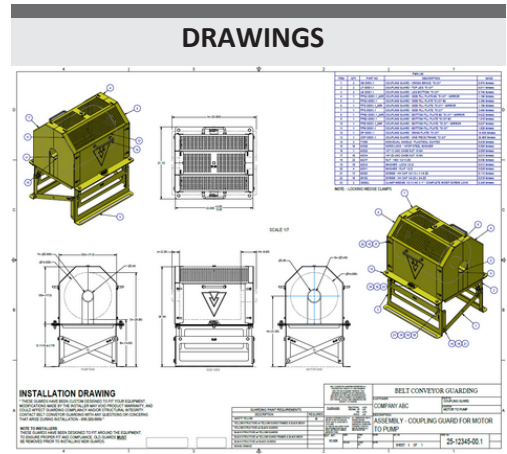
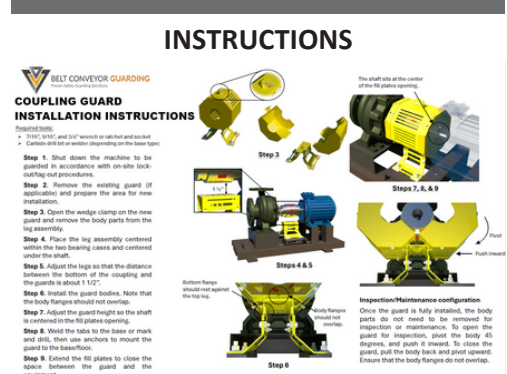

When discussing guarding systems, the most important factor is whether the system effectively protects your workers from potential hazards. Since safety guarding is a financial investment, it's also essential to consider the Return on Investment (ROI) when choosing the right solution.

WORKER SAFETY SHOULD BE EVERYONE'S TOP PRIORITY

BELT CONVEYOR GUARDING INCREASES YOUR RETURN ON INVESTMENT BY:

- › Improving worker safety & reducing injuries and lost time.
- › Reducing unscheduled and unnecessary downtime with easy-to-handle guards.
- › Minimizing maintenance time with user-friendly, easy-access guarding.
- › Reducing the risk of citations and fines with compliant guarding.
- › Allowing for small repairs or routine maintenance to be done quickly, reducing equipment breakdowns.



NOW THAT YOU HAVE COMPLIANT GUARDS, HOW DO YOU KEEP THEM THAT WAY?

For years, standard practice has been to forget about the guards until they were non-compliant again.

GUARD MAINTENANCE PROGRAMS SHOULD CONSIST OF:

- › Regularly scheduled inspections of installed guarding.
- › Keeping guarding compliant with updated standards and regulations.
- › Ensuring all guarding stays securely in place and requires a tool for removal.
- › Replacing any damaged or worn guarding promptly by using Belt Conveyor Guarding's identification system to easily order replacement parts.



ERGONOMICS OUTLOOK

When an unexpected equipment breakdown occurs, one of the first things that happen after the machine is locked out is the need to remove Safety Guards in order to access the equipment. Also, one of the last things after repair work is completed is the need to put the guards back in place before the machinery is powered up.

Essential questions to include in your inspection:

- › How easy and quick can your guards be removed and put back in place?
- › Does this require additional manpower?
- › Is additional equipment, such as forklifts or overhead lifts, required?
- › How much time does this add to your unexpected downtime?
- › What does this extra time cost you in lost production?

GUARD SEATS

Guard Seats securely hold the lower portion of the guard, eliminating the need for bottom fasteners. Used on Barriers and Flat Guard Legs, Guard Seats improve the ergonomics and functionality of removing and reinstalling flat guards.

EASY TO INSTALL

- › Barrier posts and Flat guard legs are shipped complete with wedge clamps and guard seats installed
- › Single seat or double seat brackets are suitable for most guard applications
- › Install at varying heights for ground clearance and elevation changes

EASY TO MAINTAIN

- › Compact design with no sharp edges
- › Double guard seats include provisions for pull cord eyelets
- › Makes installation and removal significantly more efficient



Close-up view of guard seats at two different heights



Double seat brackets with provisions for pull cord eyelets



Single bracket featuring compact design and no sharp edges



When designing safety guarding, it's crucial to ensure that mesh openings or ventilation slots are small enough to prevent access to potential hazards. Guarding must also be installed at a safe distance from the hazard, factoring in the size of any openings.

Health and safety legislation, while varying across sectors and geographies, frequently references standards such as ANSI, CSA, and ISO in sections related to equipment safety and equipment guarding. When such references are made, regulations mandate compliance with the referenced standard.

Belt Conveyor Guarding's Safety is compliant with opening size and distance requirements outlined in ANSI B.11.19-2019, CSA Z432:23 and ISO 13857-2019 Machine Safety and Safe Distance Standards. Our Safety Gauge provides stakeholders and maintenance teams an easy method to determine if guarding meets applicable standard requirements, making it an essential tool for the evaluation of guard compliance. Incorporating our Safety Gauge into your guard inspection process ensures guarding is assessed effectively to ensure worker safety and compliance.

SAFETY GAUGE

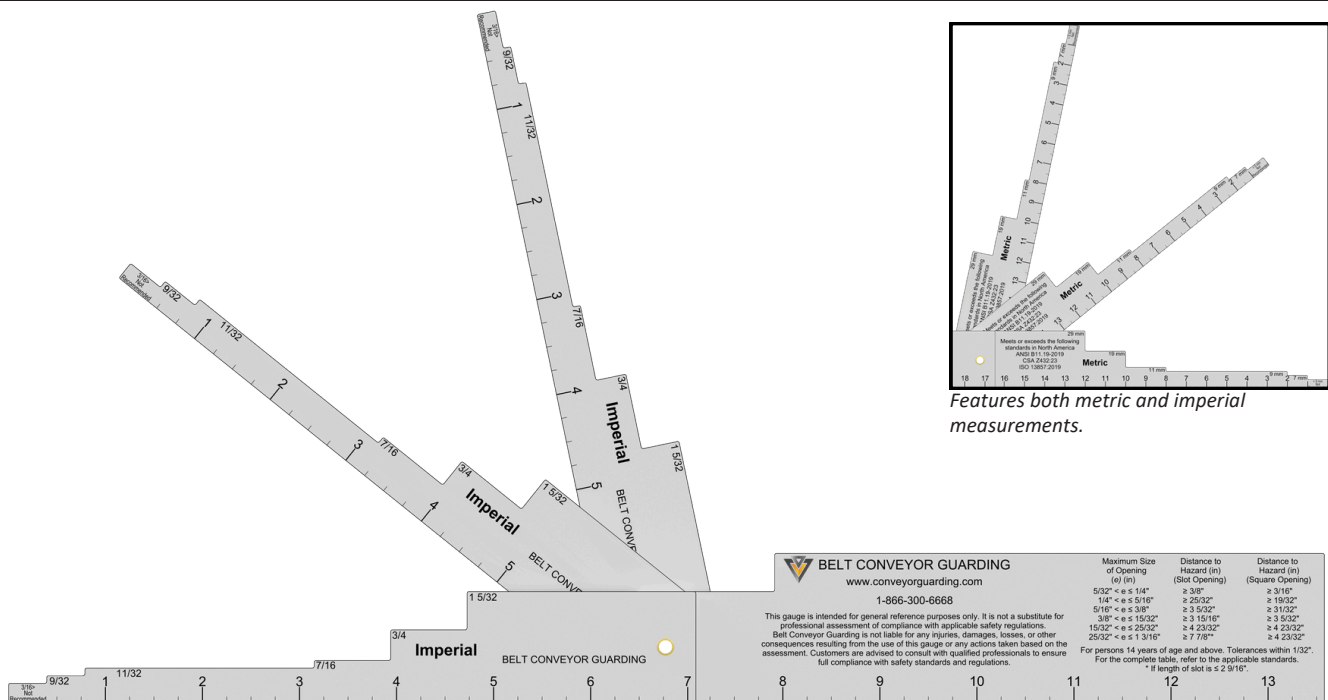

HOW TO USE OUR SAFETY GAUGE

Our safety gauge is designed to easily determine the allowable mesh size and the required distance between the guarding system and the hazard. Simply insert the safety gauge into mesh openings or slots as shown in the figures below. If the tip of the safety gauge can touch the guarded equipment, the guarding is not compliant, either due to opening size or the position and distance of the guard relative to the hazard.

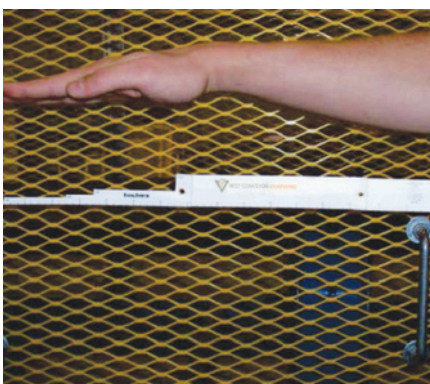

MESH SIZES AND TYPES

Expanded metal and welded wire mesh are essential components in the design and manufacture of safety guarding. We prioritize ensuring that the opening sizes in our guarding solutions provide adequate protection for workers while meeting all compliance requirements. Below are examples of standard and custom sizes commonly used in our guard designs.

EXPANDED METAL MESH

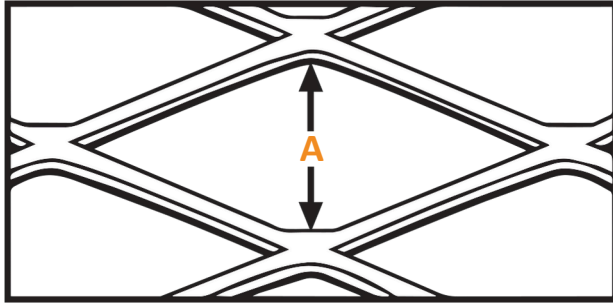

FLAT GUARDS MESH SIZES

MESH SIZE	A	B
5/16" #18 Flattened	0.172"	3/8"
3/4" #13 Flattened	0.688"	4 23/32"
1 1/2" #13 Flattened	1.063"	4 23/32"

B - distance from hazard

WELDED WIRE MESH

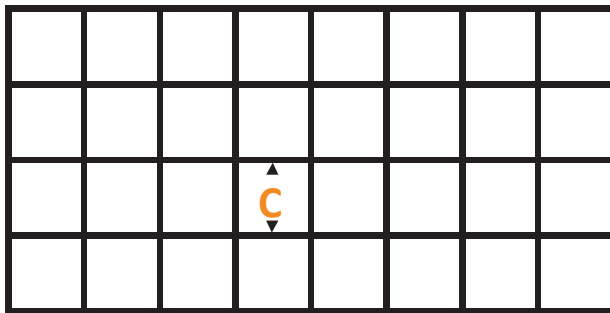

BELLY GUARDS MESH SIZES

MESH SIZE	C	D
1" x 1" - 10 Gauge	0.865"	4 23/32"
1 1/2" x 1 1/2" - 10 Gauge	1.365"	7 28/32"
3" x 3" x 1/4"	2.750"	33 15/32"

D - distance from hazard

MESH COLORS

- › Our guarding typically comes in standard safety yellow, however, it is possible to accommodate requests for alternative color options at the request of the customer.
- › We often recommend optional black mesh because it is easier on the eyes, provides better visibility, and allows for the use of touchless measuring devices without having to remove the guard.

EXPANDED METAL MESH
STANDARD SAFETY YELLOW

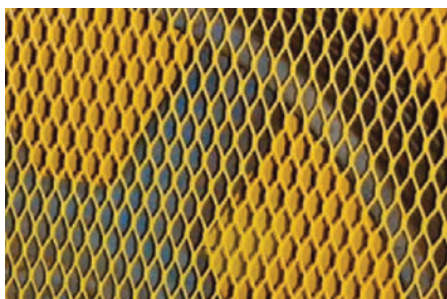

OPTIONAL BLACK MESH

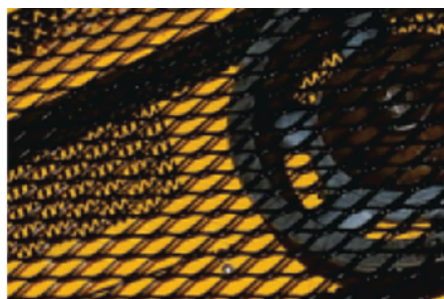

WELDED WIRE MESH
STANDARD SAFETY YELLOW

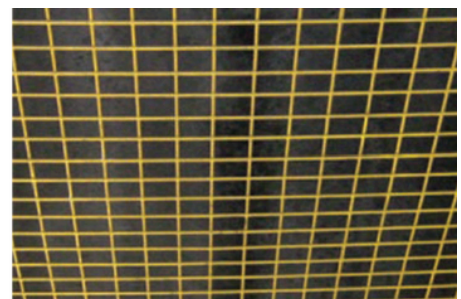

A safety guarding assessment serves as an essential starting point in developing an effective safety guarding policy. It helps identify hazards, verify compliance with relevant legislative standards, and educate stakeholders on the necessary safety guarding practices and procedures to ensure worker safety in an efficient and effective manner.

GUARDING TECHNICIANS WILL:

- › Visit your site personally to assess equipment hazards and evaluate risk associated with all equipment within the project scope.
- › Meet with stakeholders to review the assessment findings and discuss operational needs.
- › Measure equipment to design custom functional guarding solutions tailored to your unique needs.
- › Photograph equipment for the purpose of highlighting hazard locations in the Guarding Assessments.
- › Recommend appropriate guarding solutions or additional control measures to ensure compliance with relevant standards and regulations.

OTHER BENEFITS INCLUDE:

- › Discovering solutions to reduce unnecessary workplace injuries.
- › Identifying ineffective guarding systems for replacement to ensure full industry compliance.
- › Gaining a clear understanding of the requirements and scope of a tailored guarding project
- › Enhancing productivity by implementing functional guarding that integrates seamlessly with your equipment.
- › Minimizing equipment downtime during maintenance with efficient guarding that offers ease of use and reduces the need for unnecessary equipment shutdowns.

GUARDING ASSESSMENT REPORT INCLUDES:

- › An itemized report featuring photos of non-compliant equipment and/or guarding.
- › A risk analysis for all assessed equipment, including compliant guarding solutions.
- › A description of guarding deficiencies in alignment with applicable standards and regulations.
- › A recommendations report detailing suggested upgrades or additional controls for existing guards.
- › A searchable and sortable spreadsheet listing all equipment items identified in the report with the equipment locations, risk ratings, solutions, and costs for easy prioritization.
- › An itemized quote outlining the cost to supply compliant guarding for each assessed piece of equipment.

OUR SERVICES INCLUDE:

- › Risk identification
- › Risk management solutions
- › Cost projections & detailed breakdowns
- › Customized guarding designs & fabrication
- › On-site equipment measurements & photography
- › On-site training for installers and stakeholders



RISK MATRIX & REPORTS

ONCE A SAFETY GUARDING ASSESSMENT HAS BEEN COMPLETED, THIS MATRIX WILL HELP YOU PRIORITIZE YOUR GUARDING PROJECT.

P = PROBABILITY OF CONTACT
S = INJURY SEVERITY
G = GUARDING FACTOR

- Overall risk score range: 4-18.**
Risk is acceptable. No action required.
- Overall risk score range: 20-26.**
Additional controls should be considered.
- Overall risk score range: 40-160.**
Risk is unacceptable. Guarding is needed to reduce risks to acceptable range.

OVERALL RISK = $\frac{P \times S}{G}$		GUARDING FACTOR			
		0.1	0.3	0.6	0.9
PROBABILITY OF CONTACT (P) INJURY SEVERITY (S)	16	160	53	26	18
	12	120	40	20	13
	8	80	26	13	9
	6	60	20	10	6
	4	40	13	6	4

RISK SUMMARY

Risk summaries are developed using this risk matrix. These reports offer stakeholders a detailed breakdown of identified hazards and equipment issues. This list is organized by specific equipment, with references to quote IDs and line numbers, allowing for easy cross-referencing between documents.

Risk Summary

Prepared Exclusively for

Company ABC

by

Belt Conveyor Guarding



Equipment:	Crusher 123				Quote ID: 23-12345	
Overall Risk (P X S) / G	Equipment Section	Probability of Contact (P)	Injury Severity (S)	Guarding Factor (G)	Quote Lines	Equipment Price
53.3	Coupling	4	4	0.3	1	\$XXXX
10.0	Gland Seal	2	3	0.6	Not Quoted	Not Quoted
26.7	Shaft	4	4	0.6	Not Quoted	Not Quoted
Total						\$0.00

Equipment:	Conveyor XYZ				Quote ID: 23-12346	
Overall Risk (P X S) / G	Equipment Section	Probability of Contact (P)	Injury Severity (S)	Guarding Factor (G)	Quote Lines	Equipment Price
160.0	Tail Pulley	4	4	0.1	1	\$XXXX
120.0	Trough Rollers	4	3	0.1	2	\$XXXX
120.0	Return Rollers	4	3	0.1	3	\$XXXX
40.0	Head Chute Door	4	3	0.3	Not Quoted	Not Quoted
Total						\$0.00

RECOMMENDATION REPORTS

Recommendation reports provide a reference list of deficiencies that can be addressed by your company in-house. These reports are straightforward and have been designed for distribution to millwrights or maintenance teams. The reports feature the assessed risk level of hazards and offer suggested corrective actions. Using these reports allows for the quick generation of work orders, and the risk ratings simplify task prioritization.

Recommendation Report

Prepared Exclusively for

Company ABC

by

Belt Conveyor Guarding



Equipment:		Crusher 123
Risk	Equipment Section	Recommendation:
26.7	Shaft	Sharp edges on the existing guard create a cut hazard. It is recommended that Company ABC covers the exposed edges of guarding mesh to reduce hazards.

Equipment:		Conveyor XYZ
Risk	Equipment Section	Recommendation:
40	Head Chute Door	Workers can access hazard through the head chute door without requiring a tool. It is recommended that Company ABC secure the chute door with a lock to prevent unauthorized worker access.



GUARDING ASSESSMENT

The assessment report includes equipment references, risk ratings, photos highlighting safety deficiencies, and recommended solutions. If deficiencies or non-compliance are identified, the hazards are outlined, along with references to the relevant legislative standard clauses. A comprehensive list of applicable regulations and standards is provided at the end of the report.

Equipment ABC



4321



BELT CONVEYOR GUARDING
Proven Safety Guarding Solutions

Contents

V-Belt

Quote ID: 25-54321 **Line:** 1

Guarding Solution:
V-Belt Guard

Hazards:
Workers have access to the exposed belt and sheaves.
There is no existing guard.

160

Risk: Unacceptable

OHSA Reg.851 S.24 & 26 and CSA Z432-23
4.1.5, 9.1.1 & 9.3.2

www.conveyorguarding.com

Stay Away – Stay Safe

The example above is based on an assessment of a V-belt. Other types of assessed equipment may vary in appearance and requirements.

Photographs with arrows are used to correlate identified equipment deficiencies with their specific locations on the equipment. This visual approach ensures clear identification of hazard locations and links them to detailed descriptions of the associated risks. This information equips stakeholders with the necessary insights to develop and implement an effective guarding project.

Crusher 123



9999



BELT CONVEYOR GUARDING
Proven Safety Guarding Solutions

Contents

Shaft

Quote ID:
Assessment Only

Hazards:
Workers have access to the rotating shaft.
Workers can reach around the existing guard and sharp edges create a cut hazard.

Recommendations:
It is recommended that Company ABC extend the existing guard to close the gap below the bottom of the guard and the surface below, and cover any exposed edges of guard mesh to reduce worker access to hazards.

26.7

Risk: Additional controls should be considered.

OSHA 1910.212(a)(1), 1910.219(c)(4)(i), and
1910.219 (m)(1)(ii)

www.conveyorguarding.com

Stay Away – Stay Safe

Occupational Safety & Health Administration





BELT CONVEYOR GUARDING
Proven Safety Guarding Solutions

Contents

www.conveyorguarding.com

Stay Away – Stay Safe



LAYOUT MAPS

Maps are often used in reports to communicate the position of proposed guarding for conveyors and larger pieces of equipment. These maps show stakeholders where each quote line item from a particular quote would be placed on equipment and assist in correlating each guarding solution with the associated hazard, risk level, and equipment photographs.

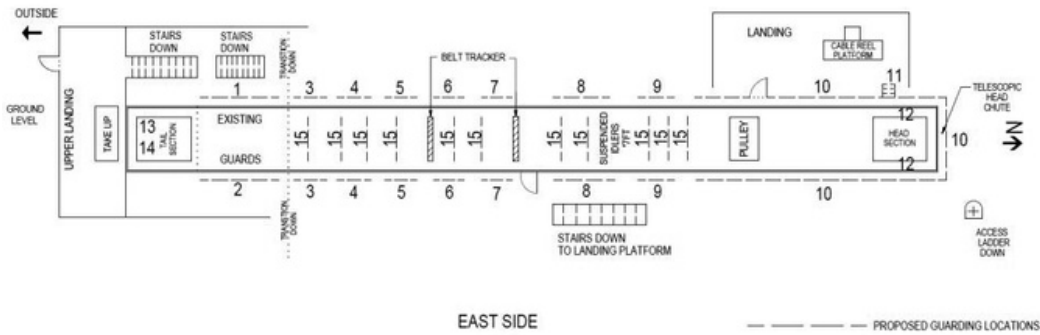

QUOTES



BELT CONVEYOR GUARDING
 a Division of Vandergeest Inc.
 3478 Penetanguishene Road R.R. #1
 Barrie, ON L4M 4Y8
 Canada
 866-300-6668
 Fax: 705-725-8835
www.conveyorguarding.com

Quotation

Quote Date: 01/01/18
 Quote ID: 15-17032
 Sales Representative:

Quote To: Company ABC

Ship To: Company ABC

Contact:

Fax:

Customer Reference

INFEEED CONVEYOR

Terms	Tax Status	FOB Point	Ship Via	Preferred Carrier	Freight
N30	Not Exempt, Tax Group ID: E				Billed

Line	Quantity	Part - Description	UM	Unit Price	Extension
1	1.00	0009M MODULAR BARRIER GUARDING FOR DRIVE SIDE LOCATION - #1	EA		
2	1.00	0009F CUSTOM 67 1/2" X 48 7/8" FLAT GUARD ASSEMBLY COMPLETE WITH 2" GUARD MOUNTING RAIL LOCATION - #2	EA		
3	2.00	0009F CUSTOM 18" X 7" FLAT GUARD ASSEMBLY COMPLETE WITH MOUNTING HARDWARE LOCATION - #3	EA		
4	8.00	71303 FLAT GUARDING - HANDLES KIT	EA		

***REFERENCE DWG#15-17032 FOR PROPOSED GUARDING LOCATIONS**

NOTE: SMALL ORDERS MAY BE SUBJECT TO PAINT SET UP CHARGE

Additional Notes:

- o All Mounting Hardware is included.
- o All guards to be powder coated orange.
- o Freight and Customs not included.
- o Lead time is 2 - 3 weeks from Receipt of Purchase Order.

Payment Terms:

- o Invoiced upon shipment of guards, due net 30 days.
- o Payable in US Funds.

Warranty:

Belt Conveyor Guarding warrants all parts and materials to be free of defects for a period of 1 year. Any alterations to the guards by others, including improper mounting and/or failure to replace tie wraps will void this warranty.

Sub Total:
 Service Charge Total:
 Total:

Guarding Quotes are included with assessment reports. Quotes are broken down by equipment, and further, by line item indicating the cost of each guard solution that has been recommended for hazard control.



THE ULTIMATE GUARDING FASTENER

The Smart Wedge Clamp is designed to remain securely in place while allowing for the quick and easy removal and replacement of guards. This fastener ensures that you never lose your guard locking mechanism, and ensures compliance with relevant standards.

BENEFITS OF LOCKING WEDGE CLAMPS

- › No hassle guard installation mechanism pivots open and closed with no loose parts
- › Install guards using Smart Wedge Clamps in less than 15 seconds
- › Guards can be removed easily for maintenance
- › Zinc plated for durability (also available in stainless steel)
- › Patented design uses a cable tie to ensure the Wedge Clamp remains locked securely in place



Assembly includes: Smart Wedge Clamp, nut, lock washer, and cable tie

PART NUMBERS AND TECHNICAL SPECIFICATIONS

SMART WEDGE CLAMPS				
DESCRIPTION	PART #	MATERIAL	THREAD SIZE	UNITS INCLUDED
Smart Wedge Clamp Assembly 3/8"	71327	Zinc	3/8" - 16 NC x 1"L	1
Smart Wedge Clamp Assembly 3/8"	71327S	Stainless	3/8" - 16 NC x 1"L	1
Smart Wedge Clamp Assembly 1/2"	70100	Zinc	1/2" - 13 NC x 1"L	1
Smart Wedge Clamp Assembly 1/2"	70100S	Stainless	1/2" - 13 NC x 1"L	1
Smart Wedge Clamp Assembly 1/2"	71259	Zinc	1/2" - 13 NC x 1½"L	1
Smart Wedge Clamp Assembly Weld On	71370	Zinc	No Threads	1

Smart Wedge Clamps are sold in quantities of 50



Please Note: A cable tie or other device, as shown above, MUST be installed through the Wedge Clamp in the "closed" position to ensure compliance with ANSI B11.19-2019 sec. 8.1.4.1 & 8.2.2, CSA Z432-2023 sec. 9.3.2 & 9.3.3.4, and ISO 14120-2015 sec. 5.19 which require a "tool to remove".



LOCKING WEDGE CLAMP

Our Locking Wedge Clamp uses a set screw system, designed for applications where using a cable tie is not desirable.

BENEFITS OF LOCKING WEDGE CLAMPS

- › No hassle guard installation mechanism pivots open and closed with no loose parts
- › Install guards using Locking Wedge Clamps quickly and easily
- › Guards can be removed easily for maintenance
- › Zinc plated for durability (also available in stainless steel)
- › Patented set screw design locks and unlocks using an Allen key
- › When unlocked, the toggle bar rotates for easy installation and removal of guards



PATENTED

Assembly includes: Locking Wedge Clamp, hex nut, and lock washer

PART NUMBERS AND TECHNICAL SPECIFICATIONS

LOCKING WEDGE CLAMPS				
DESCRIPTION	PART #	MATERIAL	THREAD SIZE	UNITS INCLUDED
Locking Wedge Clamp Assembly 1/2"	71307	Zinc	1/2" - 13 NC x 1"	1
Locking Wedge Clamp Assembly 1/2"	71307S	Stainless	1/2" - 13 NC x 1"	1

Locking Wedge Clamps are sold in quantities of 50

1

In open position, set screw allows quick installation or removal of guards



2

Locking wedge clamp body shows built in set screw

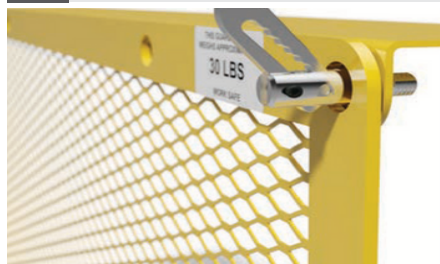

3

With set screw tightened into place using an Allen key



Flat guards are a versatile guarding solution, suitable for a wide range of rotating equipment and conveyor applications.

EASY TO INSTALL

- › Standard and custom sizes available
- › Mounts easily with 2 or 4 wedge clamps
- › Other easy mounting options are available

EASY TO MAINTAIN

- › Guards remove in seconds for equipment access
- › Standard guards are interchangeable

BUILT TO LAST

- › Heavy-duty steel construction
- › Powder coated for increased durability



FLAT GUARD DESCRIPTIONS AND PART NUMBERS				
DESCRIPTION	PART #	WEIGHT (lbs)	A (IN)	B (IN)
24" X 50"	70077	26.1	24	50
30" X 50"	70610	29.4	30	50
36" X 50"	70149	32.7	36	50
24" X 60"	71112	33.1	24	60
30" X 60"	71113	37.6	30	60
36" X 60"	71114	42	36	60
24" X 72"	71235	38	24	72
30" X 72"	71264	42.9	30	72
36" X 72"	71265	47.6	36 <td 72	

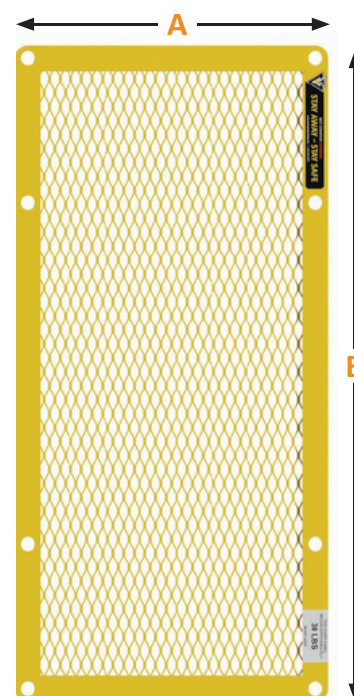

Expanded Mesh Demonstrated In Rendering

CUSTOMIZE FLAT GUARDS WITH:

- › **Laser Cut Identification:** for easy guard reference during maintenance
- › **Handles:** for easy lifting and re-positioning of guards
- › **Access/Inspection Doors:** for increased productivity
- › **Signs:** Standard and custom signs can be added to visually convey safety messages
- › **Black Mesh:** Improves visibility and allows for the use of touchless measuring devices



FLAT GUARD MOUNTING OPTIONS

BENEFITS OF GUARD MOUNTING LEGS

- › Reduces guarding installation times
- › Eliminates the need for custom fabricated supporting framework
- › Powder coated for increased durability
- › Ensures consistency and compliance
- › Custom leg sizes ensure guards are installed correctly
- › Legs are shipped with hardware installed



1 Mounting leg horizontal standoff

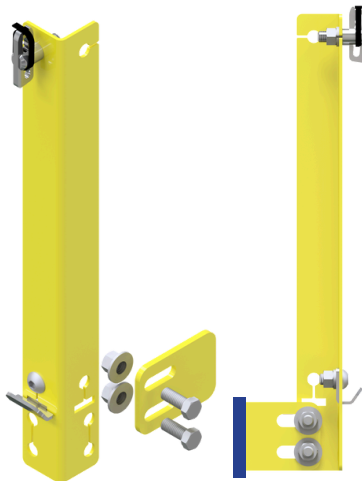

2 Mounting leg vertical standoff

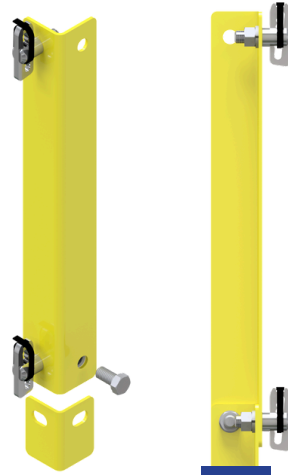

3 Mounting leg adjustable horizontal standoff

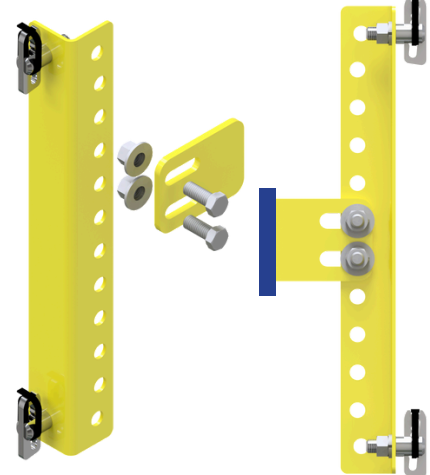

Represents a location where standoff is to be welded to equipment or structure.

- › **Horizontal Standoff:** Length customized to suit obstructions
- › **Vertical Standoff:** Ideal for mounting legs on “TOP” of structure
- › **Adjustable Standoff:** Multiple holes for maximum adjustability during installation



GUARD MOUNTING LEG TYPES

1 Single leg assembly



2 Double leg assembly

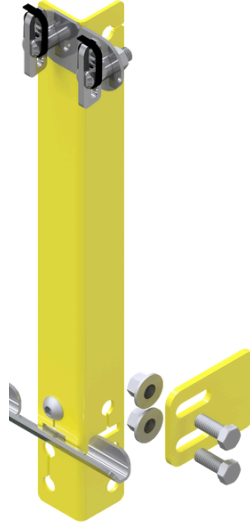

3 Single leg assembly with emergency pull cord eyelet

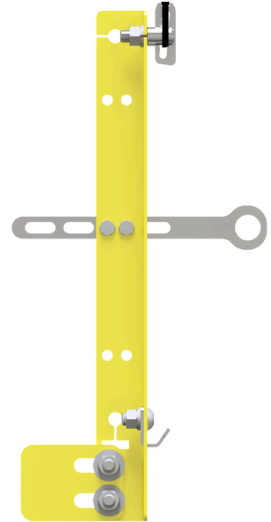

Please Note: Double leg assemblies are used for continuous runs of guards.

GUARD MOUNTING RAILS



Custom lengths and widths are available to suit your application.



MODULAR BARRIER GUARDS

Modular barrier guards are self-supporting and designed for various pumps and rotating equipment applications. They are commonly used to safeguard tail sections on conveyors.

EASY TO INSTALL

- › Self-supporting structure
- › Customized for each application
- › No welding or cutting required
- › Sets up easily with modular bolt-together design
- › Posts/Legs are shipped fully assembled

EASY TO MAINTAIN

- › Guards remove in seconds for equipment access

BUILT TO LAST

- › Heavy-duty steel construction
- › Powder coated for increased durability



CUSTOMIZE YOUR BARRIER GUARDS WITH ANY OF THE FOLLOWING OPTIONS:

- › **Service/Inspection Doors:** Access smaller areas for inspection or maintenance (with proper procedures in place)
- › **Laser Cut Identification:** Easily reference equipment when performing maintenance tasks
- › **Handles:** Ergonomically friendly handles for easy removal of guards
- › **Access Doors:** Full entry to key areas (when proper procedures are in place)
- › **Signs:** Standard and custom signs can be added to visually convey safety messages
- › **Black Mesh:** Improves visibility and allows for the use of touchless measuring devices



Rolling safety gates are perfect for rotary car dumpers, train positioners, and other restricted areas, providing controlled traffic flow while limiting access to hazards. The gates open smoothly, ensuring easy and unobstructed access to equipment.

EASY TO INSTALL

- › Self-supporting structure
- › Customized for each application
- › No welding or cutting required

EASY TO MAINTAIN

- › Heavy-duty rollers on gates ensure smooth operation in harsh environments

BUILT TO LAST

- › Gate rollers and frames are galvanized for increased durability
- › Guard panels are powder-coated yellow for increased visibility



OUR PRODUCTS ARE COMPLIANT WITH THE FOLLOWING SAFE GUARDING STANDARDS:

MSHA		OSHA		CSA	
56/57.14112	Construction & Maintenance of Guards	1910.212 1910.219	General Industry Machine Guarding	9.3.3	Requirements for Guards
56/57.14107	Moving Machine Parts	1926.555	Construction Conveyors	7.4	Mechanical Systems
75.1722 77.400	Mechanical Equipment Guards	1917.48	Marine Terminal Conveyors	9.3.3.3	Guard Openings & Distance to Hazards
ANSI B11.19-2019		ASME B20-2018	ISO 14120-2015	Canadian Provincial Legislation	

Please note: Not all products comply with every standard clause. To ensure compliance, contact Belt Conveyor Guarding for recommended solutions.



COUPLING GUARDS

Coupling guards prevent access to exposed pinch points around couplings and rotating shaft applications, ensuring safety in the workplace.

EASY TO INSTALL

- › Self-supporting, adjustable design
- › Custom fit for each application
- › No welding or cutting required
- › Adjustable side fill plates and mounting legs

EASY TO MAINTAIN

- › Removable top for access to coupling or shaft
- › Bottom slots help reduce material build-up
- › Sectional design for ease of installation
- › Standard inspection doors provide convenient access to shafts and couplings for routine inspection and maintenance. *To be used in accordance with established safety procedures or LOTO protocols.*

BUILT TO LAST

- › Heavy-duty steel construction
- › Also available in stainless steel or aluminum
- › Powder coated for increased durability

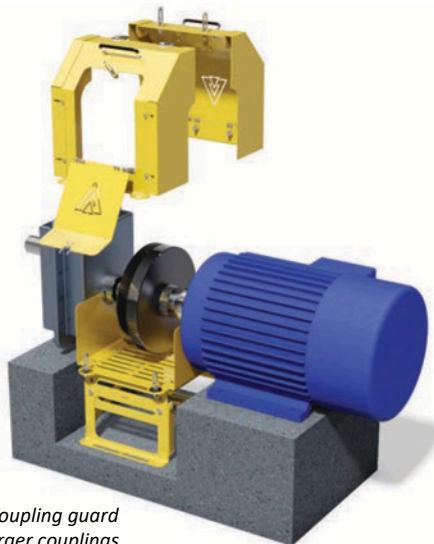

*Split coupling guard
for larger couplings*



CONTOURED DESIGN



DOOR OPEN TO SHOW ACCESS

NEED A QUOTE?

Please fill out the corresponding data sheet on page 42.

CUSTOMIZE YOUR COUPLING GUARDS WITH THE FOLLOWING OPTIONS:

- › **Laser Cut Identification:** Easily reference equipment when performing maintenance tasks
- › **Handles:** Ergonomically friendly handles for easy removal of guards



Pump guards protect workers from exposed pinch points around rotating equipment in pump applications, enhancing workplace safety.

EASY TO INSTALL

- › No need to remove sheaves during installation
- › Custom fit for each pump application
- › A variety of mounting options are available

EASY TO MAINTAIN

- › Bottom slots help reduce material build-up
- › Front guards can be easily removed to facilitate equipment maintenance
- › The enclosed design helps extend the life of belts and sheaves

BUILT TO LAST

- › Heavy-duty steel construction
- › Also available in stainless steel or aluminum
- › Powder coated for increased durability

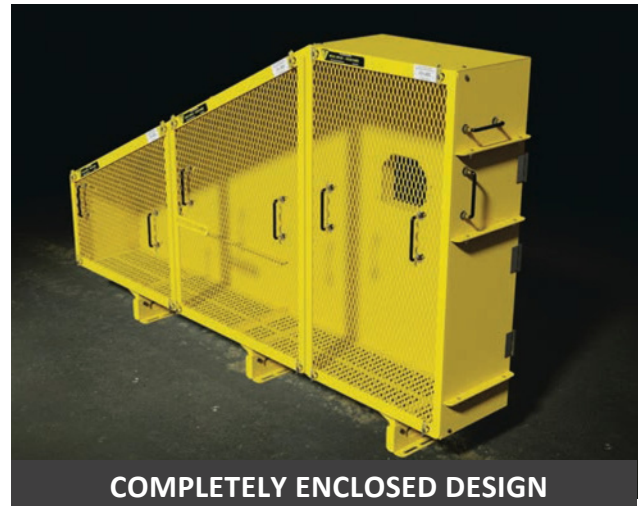
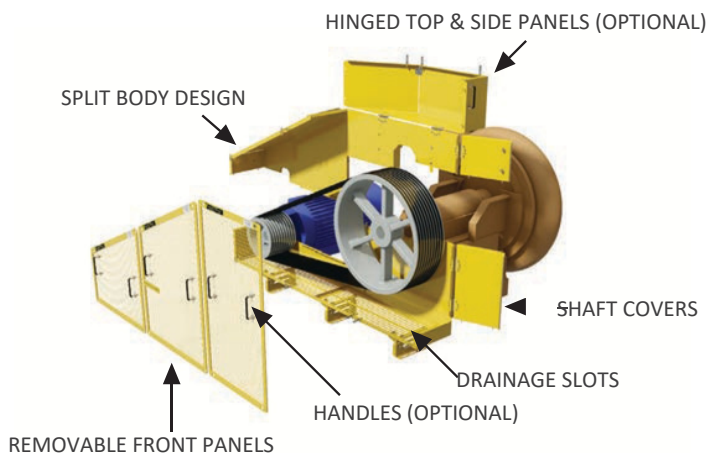

COMPLETELY ENCLOSED DESIGN



LASER CUT IDENTIFICATION

NEED A QUOTE?

Please use page 36 for orientation and complete the corresponding data sheet on pages 37 or 38.

FEATURES AND OPTIONS

- › **Removable Front Guard:** For easy belt and sheave removal
- › **Split Body Assembly:** Easy installation of guarding without sheave removal
- › **Drainage Slots:** Reduce material build-up around belts and sheaves
- › **Shaft Covers:** Ensure all moving parts are guarded
- › **Optional Removable Top:** For easy belt adjustment and sheave removal
- › **Optional Black Mesh:** Improves visibility and allows for the use of touchless measuring devices
- › **Optional Hinges and Handles:** Improve ergonomics and accessibility



V-BELT GUARDS

V-Belt guards protect workers from exposed pinch points around belts, fan drives, compressors, and crushers, ensuring a safer work environment.

EASY TO INSTALL

- › No need to remove sheaves during installation
- › Custom fit for each application
- › Mounting rails are included for ease of installation

EASY TO MAINTAIN

- › Bottom slots help reduce material build-up
- › Front guards can be easily removed to facilitate equipment maintenance
- › The enclosed design helps extend the life of belts and sheaves

BUILT TO LAST

- › Heavy-duty steel construction
- › Also available in stainless steel or aluminum
- › Powder coated for increased durability



NEED A QUOTE?

Please use page 36 for orientation and complete the corresponding data sheet on pages 39, 40 or 42.



Laser cut identification for easy equipment referencing

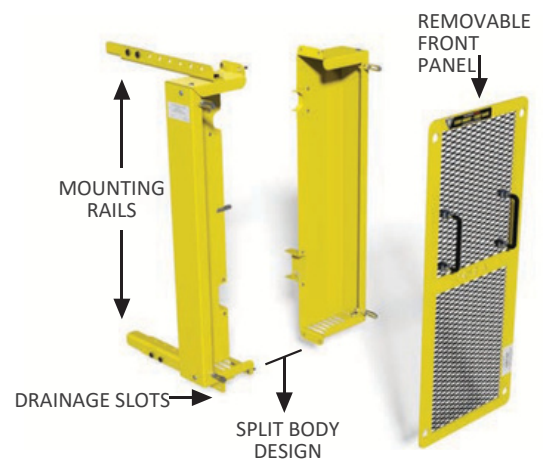

FEATURES AND OPTIONS

- › **Removable Front Guard:** For easy belt and sheave removal
- › **Split Body Assembly:** Easy installation of guarding without sheave removal
- › **Drainage Slots:** Reduce material build-up around belts and sheaves
- › **Optional Black Mesh:** Improves visibility and allows for the use of touchless measuring devices
- › **Optional Hinges and Handles:** Improve ergonomics and accessibility



Box Guards offer a customized, versatile solution for protecting hard-to-guard hazards. These guards efficiently restrict access to exposed pinch and nip points, enhancing workplace safety, and are ideal for a variety of applications.

EASY TO INSTALL

- › Shipped with mounting hardware
- › Custom fit for each application

EASY TO MAINTAIN

- › Guard removes in seconds for equipment access
- › Multiple holes to mount grease lines or auto greasers (when applicable)
- › Optional black mesh for increased visibility

BUILT TO LAST

- › Heavy-duty steel construction
- › Also available in stainless steel or aluminum
- › Powder coated for increased durability



NEED A QUOTE?

Please complete the corresponding data sheet on page 43.

1 Example of area where a box guard would be used



2 Guard installed over exposed conveyor pulley



3 Guard installed over exposed bearing



OUR PRODUCTS ARE COMPLIANT WITH THE FOLLOWING SAFE GUARDING STANDARDS:

MSHA		OSHA		CSA	
56/57.14112	Construction & Maintenance of Guards	1910.212 1910.219	General Industry Machine Guarding	9.3.3	Requirements for Guards
56/57.14107	Moving Machine Parts	1926.555	Construction Conveyors	7.4	Mechanical Systems
75.1722 77.400	Mechanical Equipment Guards	1917.48	Marine Terminal Conveyors	9.3.3.3	Guard Openings & Distance to Hazards
ANSI B11.19-2019		ASME B20-2018		ISO 14120-2015	
				Canadian Provincial Legislation	

Please note: Not all products comply with every standard clause. To ensure compliance, contact Belt Conveyor Guarding for recommended solutions.



FLANGE BEARING GUARDS

Flange bearing guards are quick and easy-to-install cap guards that prevent contact with rotating shafts on flange mount bearings to reduce rotating hazards.

BENEFITS OF FLANGE BEARING GUARDS

- › Easily mounts to bearing assembly
- › Allows access to grease nipples without removing the guard
- › Customized for a variety of flange bearing sizes
- › Slots allow for the safe inspection of shafts while equipment is in operation
- › Powder coated for increased durability
- › Durable steel construction
- › Shipped fully assembled, ready to install



NEED A QUOTE?

Please fill out the corresponding data sheet on page 44.

1

Two Bolt Option

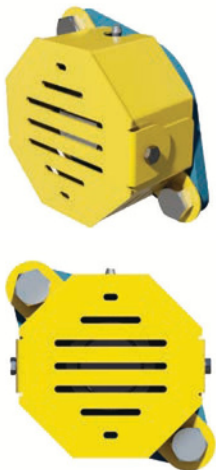

2

Three Bolt Option



3

Four Bolt Option



OUR PRODUCTS ARE COMPLIANT WITH THE FOLLOWING SAFE GUARDING STANDARDS:

MSHA		OSHA		CSA	
56/57.14112	Construction & Maintenance of Guards	1910.212 1910.219	General Industry Machine Guarding	9.3.3	Requirements for Guards
56/57.14107	Moving Machine Parts	1926.555	Construction Conveyors	7.4	Mechanical Systems
75.1722 77.400	Mechanical Equipment Guards	1917.48	Marine Terminal Conveyors	9.3.3.3	Guard Openings & Distance to Hazards
ANSI B11.19-2019		ASME B20-2018		ISO 14120-2015	
				Canadian Provincial Legislation	

Please note: Not all products comply with every standard clause. To ensure compliance, contact Belt Conveyor Guarding for recommended solutions.



RETURN IDLER BASKETS - CHAIN MOUNT

Return Idler Baskets are designed to prevent return idlers from falling in the event of failure, ensuring the safety of both workers and equipment below.

EASY TO INSTALL

- › Attaches easily using a beam-clamp assembly, complete with chain and snap links
- › No welding or cutting required

EASY TO MAINTAIN

- › Large openings eliminate build-up

BUILT TO LAST

- › Heavy-duty steel construction
- › Also available in stainless steel or aluminum
- › Powder coated for increased durability

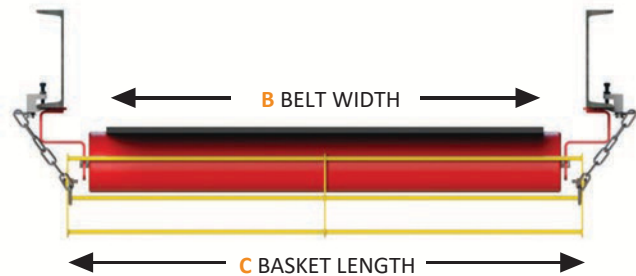

24" Baskets are used for training idlers and areas with obstructions

12" RETURN IDLER BASKET - CHAIN MOUNT				
B (BELT WIDTH)	PART NUMBER	A (BASKET WIDTH)	C (BASKET LENGTH)	BASKET WEIGHT
18" Belt	71224N	12"	24 7/8"	8.71 lbs
24" Belt	70154N	12"	30 7/8"	9.68 lbs
30" Belt	70152N	12"	36 7/8"	9.87 lbs
36" Belt	70155N	12"	42 7/8"	10.84 lbs
42" Belt	70156N	12"	48 7/8"	11.94 lbs
48" Belt	70157N	12"	54 7/8"	13.07 lbs
54" Belt	70158N	12"	60 7/8"	14.82 lbs
60" Belt	70159N	12"	66 7/8"	15.95 lbs
66" Belt	71077N	12"	72 7/8"	18.49 lbs
72" Belt	71078N	12"	78 7/8"	19.62 lbs
78" Belt	71079N	12"	84 7/8"	20.75 lbs
84" Belt	71080N	12"	90 7/8"	21.88 lbs
90" Belt	71081N	12"	96 7/8"	23.00 lbs
96" Belt	71082N	12"	102 7/8"	24.14 lbs

24" RETURN IDLER BASKET - CHAIN MOUNT				
B (BELT WIDTH)	PART NUMBER	A (BASKET WIDTH)	C (BASKET LENGTH)	BASKET WEIGHT
18" Belt	71225N	24"	24 7/8"	16.25 lbs
24" Belt	70160N	24"	30 7/8"	18.32 lbs
30" Belt	70161N	24"	36 7/8"	20.39 lbs
36" Belt	70162N	24"	42 7/8"	22.46 lbs
42" Belt	70163N	24"	48 7/8"	24.53 lbs
48" Belt	70164N	24"	54 7/8"	26.60 lbs
54" Belt	70165N	24"	60 7/8"	29.89 lbs
60" Belt	70166N	24"	66 7/8"	31.96 lbs
66" Belt	71092N	24"	72 7/8"	36.71 lbs
72" Belt	71093N	24"	78 7/8"	38.78 lbs
78" Belt	71094N	24"	84 7/8"	40.85 lbs
84" Belt	71095N	24"	90 7/8"	42.93 lbs
90" Belt	71096N	24"	96 7/8"	45.00 lbs
96" Belt	71097N	24"	102 7/8"	47.06 lbs



RETURN IDLER BASKETS - RIGID MOUNT

Return Idler Baskets with a rigid mount option help reduce vibrations on chains and effectively capture any broken or shattered idlers, ensuring enhanced safety and stability.

EASY TO INSTALL

- › Mounts around the existing return idler brackets
- › Designed to bolt directly to the conveyor frame
- › No welding or cutting required
- › No need to loosen idler bracket, eliminating belt tracking issues

EASY TO MAINTAIN

- › Large openings eliminate build-up

BUILT TO LAST

- › Heavy-duty steel construction
- › Also available in stainless steel or aluminum
- › Powder coated for increased durability

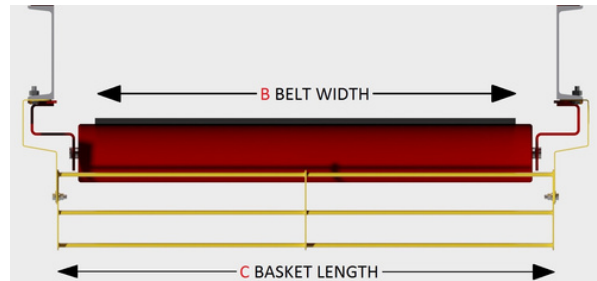
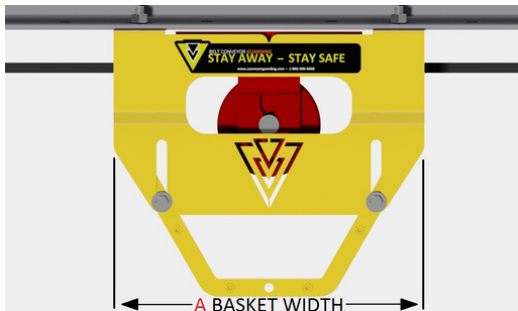
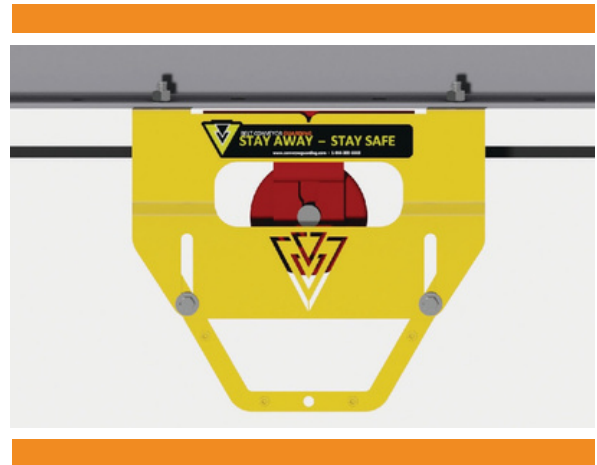

24" Baskets are used for training idlers and areas with obstructions

12" RETURN IDLER BASKET - RIGID MOUNT				
B (BELT WIDTH)	PART NUMBER	A (BASKET WIDTH)	C (BASKET LENGTH)	BASKET WEIGHT
18" Belt	71224R	12"	24 7/8"	13.7 lbs
24" Belt	70154R	12"	30 7/8"	14.8 lbs
30" Belt	70152R	12"	36 7/8"	16.0 lbs
36" Belt	70155R	12"	42 7/8"	17.1 lbs
42" Belt	70156R	12"	48 7/8"	18.2 lbs
48" Belt	70157R	12"	54 7/8"	19.3 lbs
54" Belt	70158R	12"	60 7/8"	20.4 lbs
60" Belt	70159R	12"	66 7/8"	21.5 lbs
66" Belt	71077R	12"	72 7/8"	24.5 lbs
72" Belt	71078R	12"	78 7/8"	25.6 lbs
78" Belt	71079R	12"	84 7/8"	26.7 lbs
84" Belt	71080R	12"	90 7/8"	27.8 lbs
90" Belt	71081R	12"	96 7/8"	28.9 lbs
96" Belt	71082R	12"	102 7/8"	30.0 lbs

24" RETURN IDLER BASKET - RIGID MOUNT				
B (BELT WIDTH)	PART NUMBER	A (BASKET WIDTH)	C (BASKET LENGTH)	BASKET WEIGHT
18" Belt	71225R	24"	24 7/8"	26.9 lbs
24" Belt	70160R	24"	30 7/8"	28.9 lbs
30" Belt	70161R	24"	36 7/8"	31.0 lbs
36" Belt	70162R	24"	42 7/8"	33.0 lbs
42" Belt	70163R	24"	48 7/8"	35.1 lbs
48" Belt	70164R	24"	54 7/8"	37.2 lbs
54" Belt	70165R	24"	60 7/8"	40.2 lbs
60" Belt	70166R	24"	66 7/8"	42.2 lbs
66" Belt	71092R	24"	72 7/8"	46.6 lbs
72" Belt	71093R	24"	78 7/8"	48.7 lbs
78" Belt	71094R	24"	84 7/8"	50.8 lbs
84" Belt	71095R	24"	90 7/8"	52.8 lbs
90" Belt	71096R	24"	96 7/8"	54.9 lbs
96" Belt	71097R	24"	102 7/8"	57.0 lbs



Return Idler Guards are designed for return idlers within worker reach, offering protection by preventing access to the idlers and safeguarding workers from injury caused by rotating equipment parts.

EASY TO INSTALL

- › Mounts around the existing return idler brackets
- › Designed to bolt directly to the conveyor frame
- › No welding or cutting required
- › No need to loosen idler bracket, eliminating belt tracking issues

EASY TO MAINTAIN

- › Tapered side slots reduce material build-up
- › Side panels hinge open for roller or guard maintenance

BUILT TO LAST

- › Heavy-duty steel construction
- › Also available in stainless steel or aluminum
- › Powder coated for increased durability

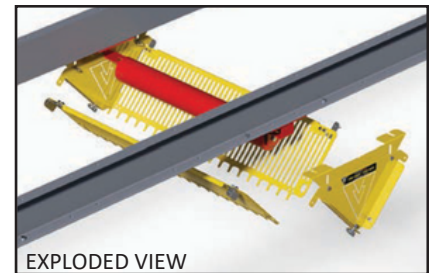
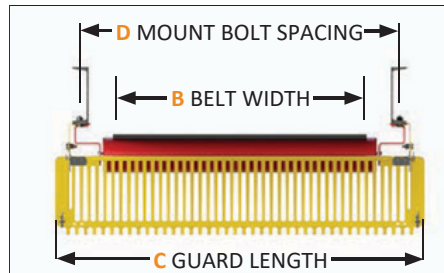

RETURN IDLER GUARDS					
B (BELT WIDTH)	PART NUMBER	A (GUARD WIDTH)	C (GUARD LENGTH)	D (BOLT SPACING)	GUARD WEIGHT
24" Belt	71198	25"	40½"	33"	43.30 lbs
30" Belt	71199	25"	46½"	39"	51.16 lbs
36" Belt	71200	25"	52½"	45"	55.01 lbs
42" Belt	71201	25"	58½"	51"	58.37 lbs
48" Belt	71202	25"	64½"	57"	65.41 lbs
54" Belt	71203	25"	70½"	63"	69.27 lbs
60" Belt	71204	25"	76½"	69"	73.12 lbs
66" Belt	71205	25"	82½"	75"	76.47 lbs
72" Belt	71206	25"	88½"	81"	80.32 lbs
78" Belt	71207	25"	94½"	87"	84.18 lbs
84" Belt	71208	25"	100½"	93"	88.03 lbs
90" Belt	71209	25"	106½"	99"	91.39 lbs
96" Belt	71210	25"	112½"	105"	98.43 lbs
102" Belt	71211	25"	118½"	111"	102.29 lbs



RETURN IDLER BELLY GUARD

Belly guards protect workers from accessing exposed return idlers on the undercarriage of conveyors. They are available for both standard and mine duty applications.

EASY TO INSTALL

- › Attaches easily using a beam-clamp assembly, complete with chain and snap links
- › Standard sizes fit most conveyors

EASY TO MAINTAIN

- › The large mesh size allows material through & reduces build-up behind the guards
- › Simply unclip guarding to quickly and easily service idlers or belts

BUILT TO LAST

- › Heavy-duty steel construction
- › Powder coated for increased durability

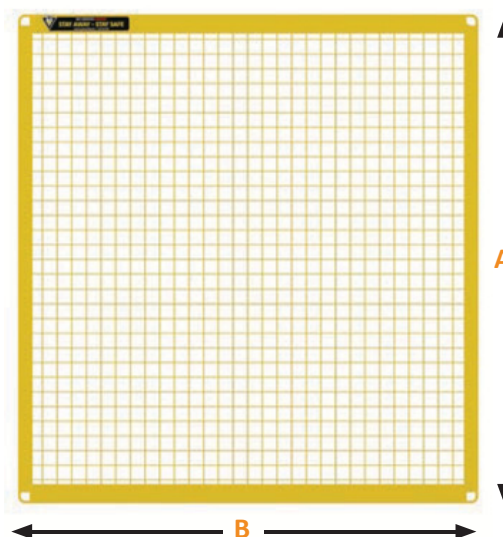

STANDARD DUTY BELLY GUARDS				
BELT WIDTH	PART NUMBER	A	B	WEIGHT
24" Belt	70773	35 1/4"	50"	28.4 lb
30" Belt	70774	41 1/4"	50"	31.7 lb
36" Belt	70775	47 1/4"	50"	35.0 lb
42" Belt	70772	53 1/4"	50"	38.3 lb
48" Belt	71083	59 1/4"	50"	46.4 lb
54" Belt	71084	65 1/4"	50"	51.8 lb
60" Belt	71085	71 1/4"	25"	42.4 lb
66" Belt	71086	77 1/4"	25"	45.6 lb
72" Belt	71087	83 1/4"	25"	48.8 lb
78" Belt	71088	89 1/4"	25"	52.0 lb
84" Belt	71089	95 1/4"	25"	55.2 lb
90" Belt	71090	101 1/4"	25"	62.7 lb
96" Belt	71091	107 1/4"	25"	74.3 lb

*Most common mesh size - 1 1/2" x 1 1/2" - 10 Gauge

MINE DUTY BELLY GUARDS			
BELT WIDTH	PART NUMBER	A	B
24" Belt	71119	35 1/4"	50"
30" Belt	71120	41 1/4"	50"
36" Belt	71121	47 1/4"	50"
42" Belt	71122	53 1/4"	50"
48" Belt	71123	59 1/4"	50"
54" Belt	71124	65 1/4"	50"
60" Belt	71125	71 1/4"	25"
66" Belt	71126	77 1/4"	25"
72" Belt	71127	83 1/4"	25"
78" Belt	71128	89 1/4"	25"
84" Belt	71129	95 1/4"	25"
90" Belt	71130	101 1/4"	25"
96" Belt	71131	107 1/4"	25"

* Mesh size - 3" x 3"



Return Idler side guards are designed to prevent access to exposed return idlers located on or around walkways and outboard rotating components, ensuring worker safety.

EASY TO INSTALL

- › Adjustable mounting brackets ensure proper guard spacing
- › Mounting rail is easily notched to bypass obstructions

EASY TO MAINTAIN

- › The removable guards allow quick, easy access to equipment, streamlining maintenance and servicing

BUILT TO LAST

- › Heavy-duty steel construction
- › Also available in stainless steel or aluminum
- › Powder coated for increased durability



OUR PRODUCTS ARE COMPLIANT WITH THE FOLLOWING SAFE GUARDING STANDARDS:

MSHA		OSHA		CSA	
56/57.14112	Construction & Maintenance of Guards	1910.212 1910.219	General Industry Machine Guarding	9.3.3	Requirements for Guards
56/57.14107	Moving Machine Parts	1926.555	Construction Conveyors	7.4	Mechanical Systems
75.1722 77.400	Mechanical Equipment Guards	1917.48	Marine Terminal Conveyors	9.3.3.3	Guard Openings & Distance to Hazards
ANSI B11.19-2019		ASME B20-2018		ISO 14120-2015	Canadian Provincial Legislation

Please note: Not all products comply with every standard clause. To ensure compliance, contact Belt Conveyor Guarding for recommended solutions.



HANDRAILS & GUARDRAILS

Handrails and guardrails are used to guide foot traffic and protect workers at elevated heights, ensuring safety in high-risk areas.

EASY TO INSTALL

- › Modular bolt-together design
- › Legs are shipped fully assembled
- › No welding or cutting required
- › Standard 60" wide x 42" high sections
- › Customized lengths and corners are available to suit specific needs
- › The required hardware is included
- › Also available for stair applications

EASY TO MAINTAIN

- › The non-tubular design allows for complete inspection
- › Damaged sections are easy to remove and replace
- › Optional kickplates are available for increased safety

BUILT TO LAST

- › 100% Powder Coated Safety Yellow for increased visibility
- › Smooth surfaces and rounded contact edges
- › Standard Mild Steel Construction
- › Other paint colors are available upon request
- › Also available in stainless steel or galvanized upon request

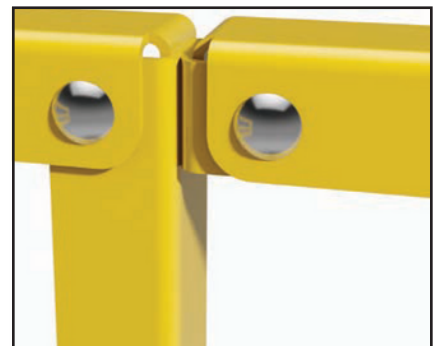
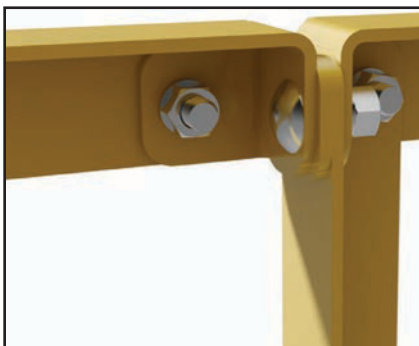

Ladder Guards are universal, ergonomically-friendly guards designed to restrict access to ladders by unauthorized operators to prevent potential health & safety risks.

EASY TO INSTALL

- › Secure in place using supplied hardware
- › Install or remove in seconds
- › Padlock hasp is included to easily lock guards in place to restrict access to unauthorized individuals
- › Built-in handles ensure ease of use and improve ergonomics
- › Standard size fits most applications
- › Custom sizes are available upon request
- › No welding or drilling required for installation

BUILT TO LAST

- › Powder coated safety yellow for durability and high visibility
- › Available in mild steel, stainless or aluminum
- › Also available in black or grey



Front View

Rear View

*Please note: a tool to remove is required to ensure compliance
Padlocks are available for purchase*



Step 1. Hang guard on ladder



Step 2. Adjust and tighten the lower hook



Step 3. Secure in place using the padlock hasp.

LADDER GUARDS

DESCRIPTION	PART	MATERIAL	COLOR	WEIGHT	WIDTH	HEIGHT	UNITS
Ladder Guard	71376	Mild Steel	Yellow	29 lbs	15"	62"	1
Ladder Guard	71376S	Stainless	Yellow	28 lbs	15"	62"	1
Ladder Guard	71376A	Aluminum	Yellow	17 lbs	15"	62"	1
Ladder Guard	71376AB	Aluminum	Black	17 lbs	15"	62"	1
Ladder Guard	71376AG	Aluminum	Grey	17 lbs	15"	62"	1
Padlock	71376L	N/A	N/A	3 lbs	N/A	N/A	1



GUARD HANGERS

Guard hangers allow you to easily hang flat guard panels onto other guards or handrails, improving ergonomics and access. They provide a convenient solution for storing guards when removed for maintenance.

EASY TO USE

- › Easily installs on flat guards
- › Hang guards on other flat guard panels or handrails

VERSATILE DESIGN

- › Can be used with new or existing guards
- › Compact design ensures there is no impact on equipment
- › Improves ergonomics, especially when combined with handles
- › Rubber coating provides anti-slip protection and prevents hangers from damaging guards.

BUILT-TO-LAST

- › Powder and rubber-coated for increased durability



GUARD HANGERS

DESCRIPTION	PART NUMBER	UNITS INCLUDED
Guard Hanger Kit	71349	2 Hangers

CABLE TIE CADDIES

The Cable Tie Caddy organizes your cable ties and ensures they are always readily available to workers.

EASY TO USE

- › Attaches to the exterior of your barrier or flat guard
- › Can be secured to your guarding or any supporting structure

BUILT-TO-LAST

- › Heavy-duty steel construction
- › Powder coated for increased durability



CABLE TIE CADDIES

DESCRIPTION	PART NUMBER	COLOR
Cable Tie Caddy	71326	Available in Safety Yellow or Red



Ergonomically designed handles enhance ease of use, offering a straightforward solution for the quick and effortless removal, handling, and installation of guards.

EASY TO USE

- › Universal - can be used for a variety of applications
- › Retrofit onto existing guards

EASY TO MAINTAIN

- › Ergonomic design
- › Improved handling of guards
- › Mount in any direction for optimal grip position

BUILT-TO-LAST

- › Rubber coated for added comfort and grip
- › Zinc plated for durability
- › Stainless steel option available for applications where corrosion is a concern



RUBBER COATED HANDLES IMPROVE ERGONOMICS AND ADD COMFORT WHEN HANDLING GUARDS



HANDLES ARE EASILY MOUNTED AND ALL HARDWARE FOR MOUNTING IS PROVIDED

HANDLES		
DESCRIPTION	PART NUMBER	UNITS INCLUDED
Handle Kit	71303	2 Handles
Stainless Handle Kit	71303S	2 Stainless Steel Handles

Each handle kit includes two handles and all required mounting hardware



SERVICE/INSPECTION DOORS

Gain access to areas quickly and easily. Service Doors are a great way to increase your productivity when servicing or inspecting equipment.

To be used in accordance with established safety procedures or LOTO protocols.

BENEFITS OF SERVICE & INSPECTION DOORS

- › Reduce time involved with equipment maintenance and inspection (greasing, etc.)
- › Retrofit onto existing guards or incorporate into new guarding systems
- › Custom sizes available for various applications
- › Durable steel construction
- › Optional laser cut warnings and identification
- › Optional guide box inserts

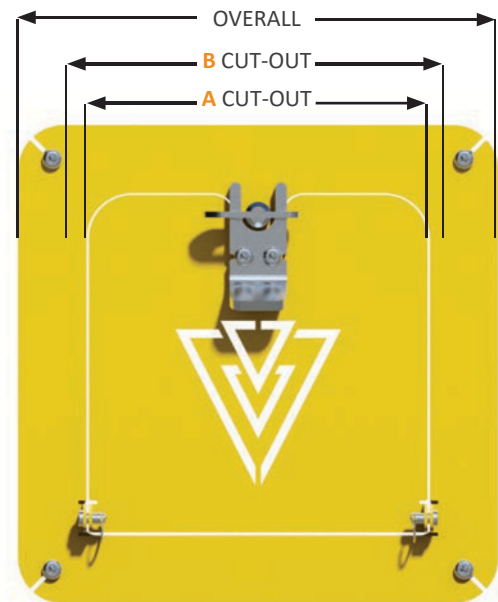

SERVICE/INSPECTION DOOR				
DESCRIPTION	PART NUMBER	A	B	C
6" x 6"	71267	5½"	6"	8½"
8" x 8"	71268	7½"	8"	10½"
10" x 10"	71269	9½"	10"	12½"
12" x 12"	71270	11½"	12"	14½"
14" x 14"	71271	13½"	14"	16½"

CUSTOMIZE A DOOR SPECIFICALLY FOR YOUR APPLICATION

Send us your dimensions and we will customize to suit!



These signs and decals are designed to improve the visibility of your safety procedures and guarding protocols. They can easily be attached to existing guards to alert workers of potential hazards and reinforce safety reminders. The signs are digitally printed on durable 3mm laminated PVC, while the vinyl decals are laminated for enhanced durability and extended lifespan. Custom signage is also available upon request.



SIGNS & DECALS		
ITEM NAME	SIGNS 7" X 10" PART NUMBER	DECALS - 5" X 7" PART NUMBER
Danger - Lock Out	31912S	31912D
Danger - Do Not Operate	31915S	31915D
Danger - Stay Clear	31916S	31916D
Danger - Keep Clear	31917S	31917D
Danger - Exposed Conveyors	31918S	31918D
Think - Zero Injuries	31914S	31914D
Think - Before You Act	31913S	31913D
Danger - Lock Out, Tag Out, Try Out	31924S	31924D
Remember - Cable Ties	31929S	31929D

THESE SIGNS WERE DESIGNED BASED ON THE FOLLOWING ANSI STANDARDS:

ANSI Z535.2-2011
Environmental and Facility Safety Signs

ANSI Z535.3-2011
Criteria for Safety Symbols



PUMP AND V-BELT GUARD DATA SELECTION CHART

DESCRIPTION	DRIVE TYPE/ORIENTATION	MOTOR/REDUCER CONFIGURATION
<p>HORIZONTAL DRIVE FLOOR MOUNT</p> <p>Split bottom to allow for install</p> <p>Use Pump Guard Data Sheet – Upright, p.37</p>		
<p>HORIZONTAL DRIVE FLOOR MOUNT (INVERSE ORIENTATION)</p> <p>Split bottom to allow for install</p> <p>Use Pump Guard Data Sheet – Inverted, p.38</p>		
<p>BASIC V-BELT DRIVE WITH CUSTOM MOUNT</p> <p>Use V-Belt Data Sheet – Upright, p.39</p>		
<p>BASIC V-BELT DRIVE WITH CUSTOM MOUNT (INVERSE ORIENTATION)</p> <p>Use V-Belt Data Sheet – Inverted, p.40</p>		
<p>BASIC V-BELT DRIVE WITH CUSTOM MOUNT WITH PIVOT MOTOR BASE</p> <p>Use V-Belt Data Sheet – Pivot, p.41</p>		

PLEASE SUBMIT PHOTOS WITH YOUR DATA SHEETS



PUMP GUARD DATA SHEET - UPRIGHT

COMPANY: _____
 CONTACT PERSON: _____
 LOCATION: _____
 PHONE: _____ FAX: _____
 EMAIL: _____
 EQUIPMENT #: _____

PLEASE SUBMIT PHOTOS WITH YOUR DATA SHEETS

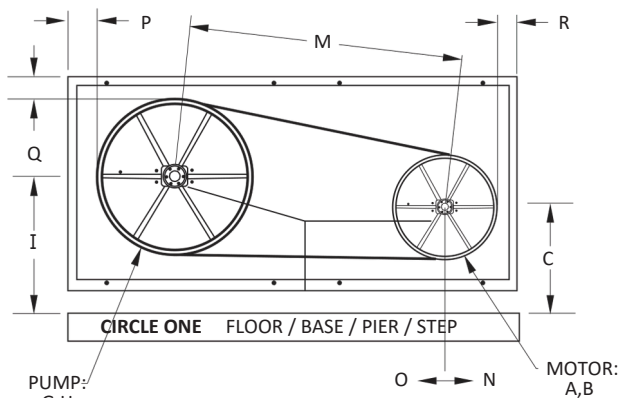

If there are obstructions, please indicate sizes and locations on sketch or additional page.

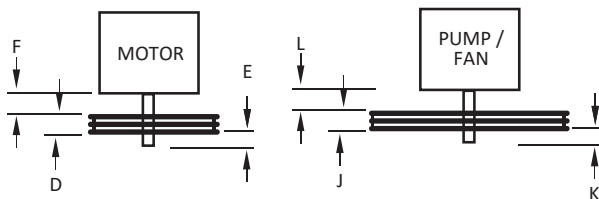

CIRCLE THE REQUIRED ORIENTATIONS

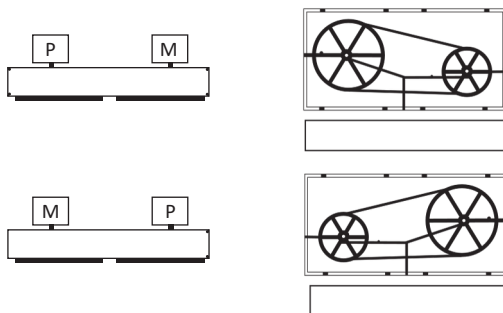

How would you like to attach the guard to base of floor?

- Concrete Wedge Anchors
- Welded On
- Standoff/Supports

INFORMATION REQUIRED

MOTOR SIDE

ITEM	DIMENSION
A - Motor Sheave Diameter	
B - Motor Shaft Diameter <i>(including keyway)</i>	
C - Motor Shaft Center Height from Floor/Base/Pier	
D - Motor Sheave Thickness	
E - Shaft Length Extending Past Sheave	
F - Shaft Length Between Sheave and Motor	

PUMP/FAN

ITEM	DIMENSION
G - Pump Sheave Diameter	
H - Pump Shaft Diameter <i>(including keyway)</i>	
I - Pump Shaft Center Height from Floor/Base/Pier	
J - Pump Sheave Thickness	
K - Shaft Length Extending Past Sheave	
L - Shaft Length Between Sheave and Motor	

OVERALL

ITEM	PLEASE INDICATE
M - Center to Center of Shafts	
N - Motor Adjustment Right	
O - Motor Adjustment Left	
P - Obstruction within 4-1/2" of Pump Sheave	Yes/No
Q - Obstruction within 4-1/2" Above Pump Sheave	Yes/No
R - Obstruction within 4-1/2" of Motor Sheave	Yes/No

SPECIFY GUARD COATING COLOR

ITEM	PLEASE INDICATE
Guard Body	Yellow/Black/Other
Guard Front Mesh Panel	Yellow/Black/Other

SPECIAL REQUIREMENTS

AREA	PLEASE INDICATE
Lubrication	Yes/No
Vibration Analysis	Yes/No
Heat Analysis	Yes/No
Speed Sensing	Yes/No
Over-Heating Concerns	Yes/No
Corrosive Area	Yes/No
Flammable Area	Yes/No
Lead Paint Abatement Area	Yes/No
Other	Yes/No



PUMP GUARD DATA SHEET- INVERTED

COMPANY: _____
 CONTACT PERSON: _____
 LOCATION: _____
 PHONE: _____ FAX: _____
 EMAIL: _____
 EQUIPMENT #: _____

PLEASE SUBMIT PHOTOS WITH YOUR DATA SHEETS

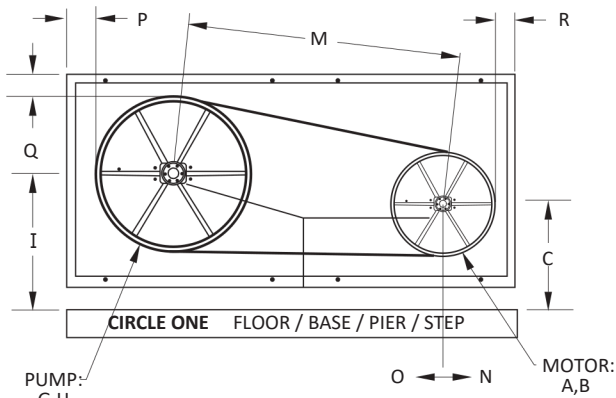

If there are obstructions, please indicate sizes and locations on sketch or additional page.

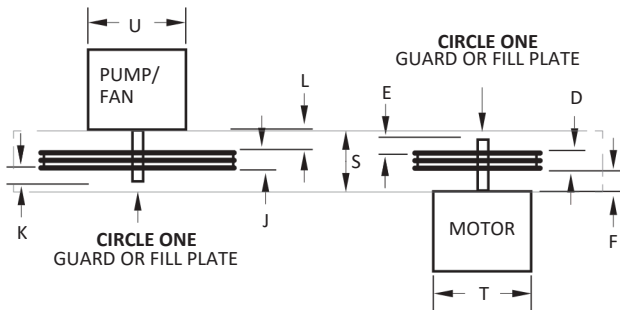

CIRCLE THE REQUIRED ORIENTATIONS

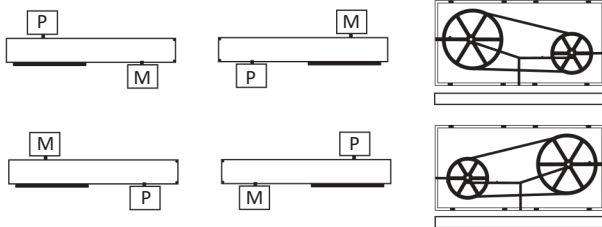

How would you like to attach the guard to base of floor?

- Concrete Wedge Anchors
- Welded On
- Standoff/Supports

INFORMATION REQUIRED

MOTOR SIDE

ITEM	DIMENSION
A - Motor Sheave Diameter	
B - Motor Shaft Diameter <i>(including keyway)</i>	
C - Motor Shaft Center Height from Floor/Base/Pier	
D - Motor Sheave Thickness	
E - Shaft Length Extending Past Sheave	
F - Shaft Length Between Sheave and Motor	
T - Width/Diameter of Motor	

PUMP/FAN

ITEM	DIMENSION
G - Pump Sheave Diameter	
H - Pump Shaft Diameter <i>(including keyway)</i>	
I - Pump Shaft Center Height from Floor/Base/Pier	
J - Pump Sheave Thickness	
K - Shaft Length Extending Past Sheave	
L - Shaft Length Between Sheave and Motor	
U - Width of Pump/Fan	

OVERALL

ITEM	PLEASE INDICATE
M - Center to Center of Shafts	
N - Motor Adjustment Right	
O - Motor Adjustment Left	
P - Obstruction within 4-1/2" of Pump Sheave	Yes/No
Q - Obstruction within 4-1/2" Above Pump Sheave	Yes/No
R - Obstruction within 4-1/2" of Motor Sheave	Yes/No
S - Maximum Width/Depth of Guard Body	

SPECIFY GUARD COATING COLOR

ITEM	PLEASE INDICATE
Guard Body	Yellow/Black/Other
Guard Front Mesh Panel	Yellow/Black/Other

SPECIAL REQUIREMENTS

AREA	PLEASE INDICATE
Lubrication	Yes/No
Vibration Analysis	Yes/No
Heat Analysis	Yes/No
Speed Sensing	Yes/No
Over-Heating Concerns	Yes/No
Corrosive Area	Yes/No
Flammable Area	Yes/No
Lead Paint Abatement Area	Yes/No
Other	Yes/No



V-BELT GUARD DATA SHEET - UPRIGHT

COMPANY: _____
 CONTACT PERSON: _____
 LOCATION: _____
 PHONE: _____ FAX: _____
 EMAIL: _____
 EQUIPMENT #: _____

PLEASE SUBMIT PHOTOS WITH YOUR DATA SHEETS

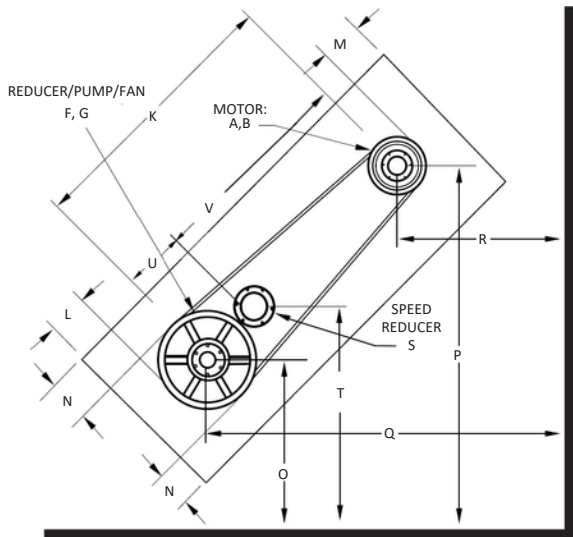

If there are obstructions, please indicate sizes, locations, and the distances from sheave(s) on the above sketch or additional page.

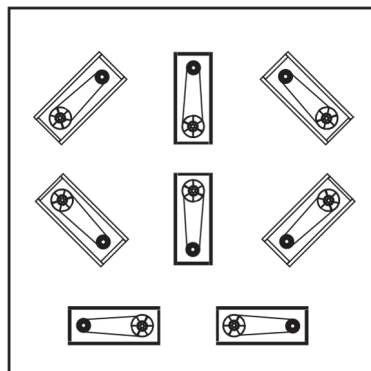
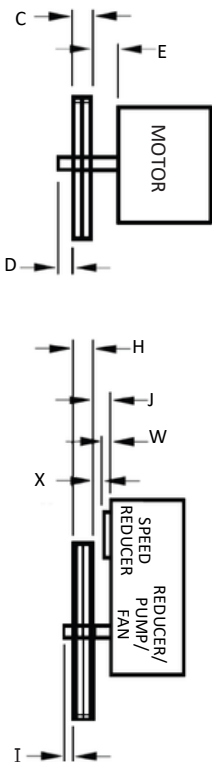

Circle the correct orientation of your equipment & indicate top location

INFORMATION REQUIRED

MOTOR SIDE

ITEM	DIMENSION
A - Motor Sheave Diameter	
B - Motor Shaft Diameter <i>(including keyway)</i>	
C - Motor Sheave Thickness	
D - Shaft Length Extending Past Sheave	
E - Shaft Length Between Sheave and Motor	

REDUCER/PUMP/FAN

ITEM	DIMENSION
F - Reducer Sheave Diameter	
G - Reducer Shaft Diameter <i>(including keyway)</i>	
H - Reducer Sheave Thickness	
I - Shaft Length Extending Past Sheave	
J - Shaft Length Between Sheave and Reducer	

OVERALL

ITEM	PLEASE INDICATE
K - Center to Center of Shafts	
L - Obstruction within 4-1/2" of Reducer Sheave	Yes/No
M - Obstruction within 4-1/2" of Motor Sheave	Yes/No
N - Obstruction within 4-1/2" of Largest Sheave	Yes/No
Speed Reducer	Yes/No

EXTRA INFORMATION

ITEM	PLEASE INDICATE
O - Distance to Reducer Sheave Obstruction	
P - Distance to Motor Sheave Obstruction	
Q - Distance to Reducer Sheave Obstruction	
R - Distance to Motor Sheave Obstruction	

SPECIFY GUARD COATING COLOR

ITEM	PLEASE INDICATE
Guard Body	*Yellow/Black/Other
Guard Front Mesh Panel	*Yellow/Black/Other

SPEED REDUCER INFORMATION

ITEM	PLEASE INDICATE
S - Speed Reducer Diameter	
T - Distance to Speed Reducer Obstruction	
U - C of Speed Reducer to C of Reducer Sheave	
V - C of Speed Reducer to C of Motor Sheave	
W - Face of Gearbox to End of Speed Reducer	
X - End of Speed Reducer to Back of Reducer Sheave	

SPECIAL REQUIREMENTS

ITEM	PLEASE INDICATE
Additional Notes	Yes/No
Guard Material	<input type="radio"/> *Mild Steel <input type="radio"/> Stainless <input type="radio"/> Aluminum <input type="radio"/> Brass
Guard Coating	<input type="radio"/> *Powder Coat <input type="radio"/> 2-Stage Pwdr Coat <input type="radio"/> Uncoated
Items marked with * are standard	



V-BELT GUARD DATA SHEET- INVERTED

COMPANY: _____
 CONTACT PERSON: _____
 LOCATION: _____
 PHONE: _____ FAX: _____
 EMAIL: _____
 EQUIPMENT #: _____

PLEASE SUBMIT PHOTOS WITH YOUR DATA SHEETS

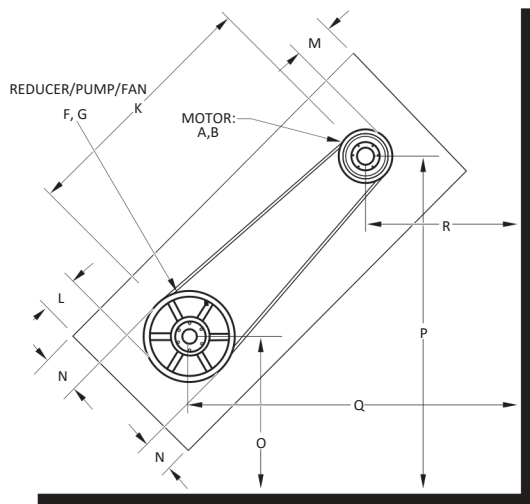

If there are obstructions, please indicate sizes, locations, and the distances from sheave(s) on the above sketch or additional page.

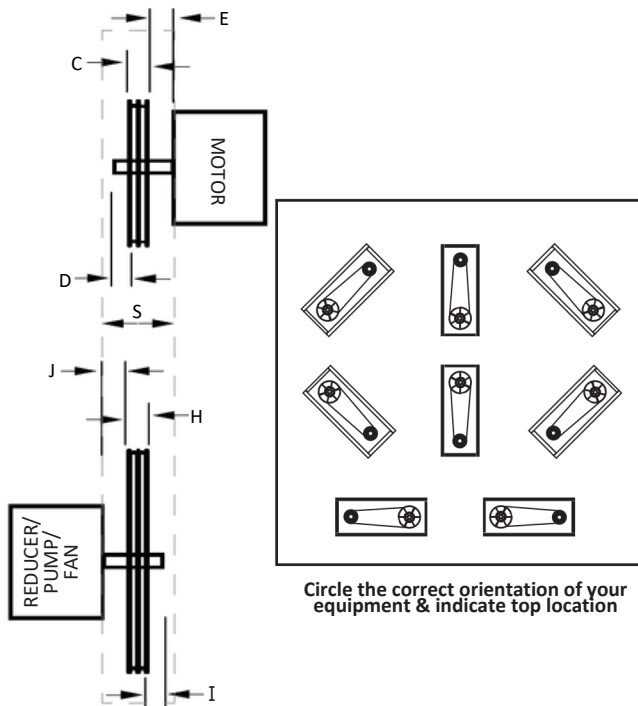

INFORMATION REQUIRED

MOTOR SIDE

ITEM	DIMENSION
A - Motor Sheave Diameter	
B - Motor Shaft Diameter <i>(including keyway)</i>	
C - Motor Sheave Thickness	
D - Shaft Length Extending Past Sheave	
E - Shaft Length Between Sheave and Motor	

REDUCER/PUMP/FAN

ITEM	DIMENSION
F - Reducer Sheave Diameter	
G - Reducer Shaft Diameter <i>(including keyway)</i>	
H - Reducer Sheave Thickness	
I - Shaft Length Extending Past Sheave	
J - Shaft Length Between Sheave and Reducer	

OVERALL

ITEM	PLEASE INDICATE
K - Center to Center of Shafts	
L - Obstruction within 4-1/2" of Reducer Sheave	Yes/No
M - Obstruction within 4-1/2" of Motor Sheave	Yes/No
N - Obstruction within 4-1/2" of Largest Sheave	Yes/No
Speed Reducer	Yes/No

EXTRA INFORMATION

ITEM	PLEASE INDICATE
O - Distance to Reducer Sheave Obstruction	
P - Distance to Motor Sheave Obstruction	
Q - Distance to Reducer Sheave Obstruction	
R - Distance to Motor Sheave Obstruction	
S - Maximum Width/Depth of Guard Body	

SPECIFY GUARD COATING COLOR

ITEM	PLEASE INDICATE
Guard Body	Yellow/Black/Other
Guard Front Mesh Panel	Yellow/Black/Other

SPECIAL REQUIREMENTS

AREA	PLEASE INDICATE
Lubrication	Yes/No
Vibration Analysis	Yes/No
Heat Analysis	Yes/No
Speed Sensing	Yes/No
Over-Heating Concerns	Yes/No
Corrosive Area	Yes/No
Flammable Area	Yes/No
Lead Paint Abatement Area	Yes/No
Motor Adjustments in/out (+/-)	
Other	



COMPANY: _____
 CONTACT PERSON: _____
 LOCATION: _____
 PHONE: _____ FAX: _____
 EMAIL: _____
 EQUIPMENT #: _____

PLEASE SUBMIT PHOTOS WITH YOUR DATA SHEETS

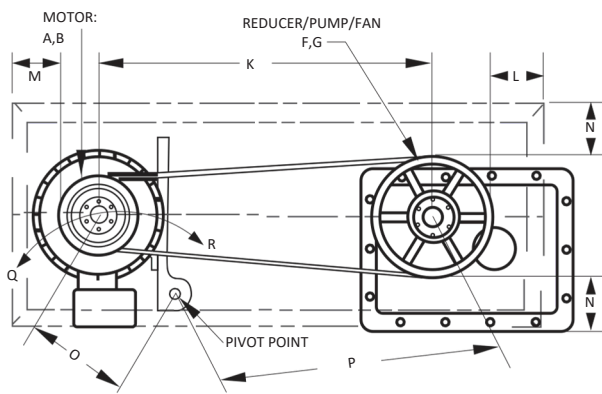

If there are obstructions, please indicate sizes, locations, and the distances from sheave(s) on the above sketch or additional page.

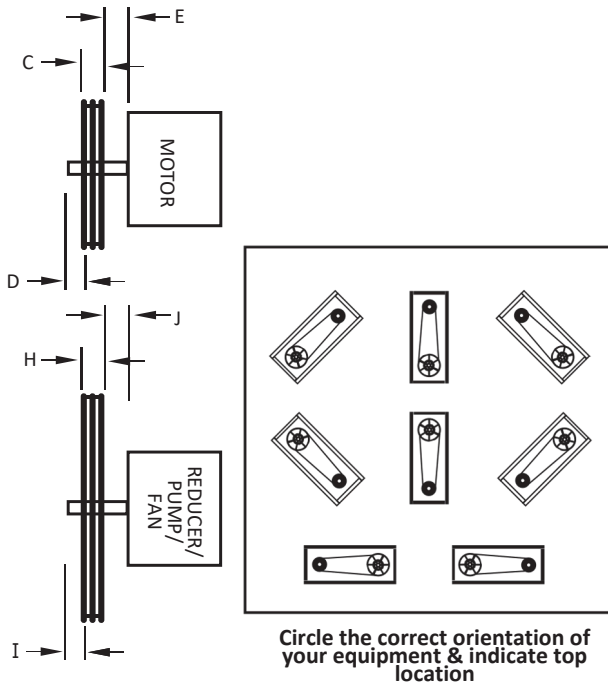

INFORMATION REQUIRED

MOTOR SIDE

ITEM	DIMENSION
A - Motor Sheave Diameter	
B - Motor Shaft Diameter <i>(including keyway)</i>	
C - Motor Sheave Thickness	
D - Shaft Length Extending Past Sheave	
E - Shaft Length Between Sheave and Motor	

REDUCER/PUMP/FAN

ITEM	DIMENSION
F - Reducer/Pump/Fan Sheave Diameter	
G - Reducer/Pump/Fan Shaft Diameter <i>(with keyway)</i>	
H - Reducer/Pump/Fan Sheave Thickness	
I - Shaft Length Extending Past Sheave	
J - Shaft Length Between Sheave & Reducer/Pump/Fan	

OVERALL

ITEM	PLEASE INDICATE
K - Center to Center of Shafts	
L - Obstruction within 4-1/2" of Reducer Sheave	Yes/No
M - Obstruction within 4-1/2" of Motor Sheave	Yes/No
N - Obstruction within 4-1/2" of Largest Sheave	Yes/No
Speed Reducer	Yes/No

EXTRA INFORMATION

ITEM	PLEASE INDICATE
O - Distance from Motor to Pivot	
P - Distance from Reducer to Pivot	
Q - Adjustment Up	
R - Adjustment Down	

SPECIFY GUARD COATING COLOR

ITEM	PLEASE INDICATE
Guard Body	Yellow/Black/Other
Guard Front Mesh Panel	Yellow/Black/Other

SPECIAL REQUIREMENTS

AREA	PLEASE INDICATE
Lubrication	Yes/No
Vibration Analysis	Yes/No
Heat Analysis	Yes/No
Speed Sensing	Yes/No
Over-Heating Concerns	Yes/No
Corrosive Area	Yes/No
Flammable Area	Yes/No
Lead Paint Abatement Area	Yes/No
Other	



COUPLING GUARD DATA SHEET

COMPANY: _____
 CONTACT PERSON: _____
 LOCATION: _____
 PHONE: _____ FAX: _____
 EMAIL: _____
 EQUIPMENT #: _____
 QUANTITY: _____

PLEASE SUBMIT PHOTOS WITH YOUR DATA SHEETS

FOR USE WHEN THERE IS NO GUARD IN PLACE

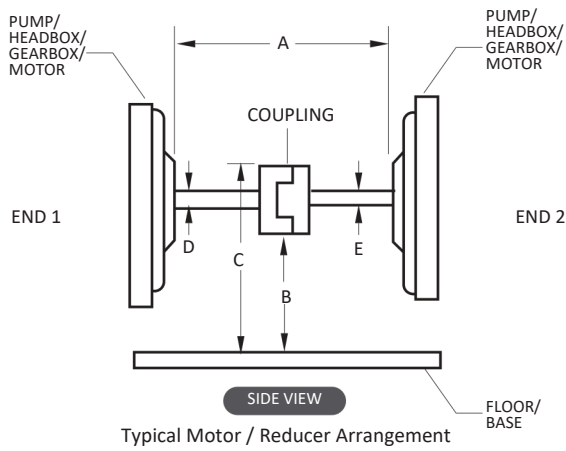

FOR USE WHEN THERE IS AN EXISTING GUARD IN PLACE

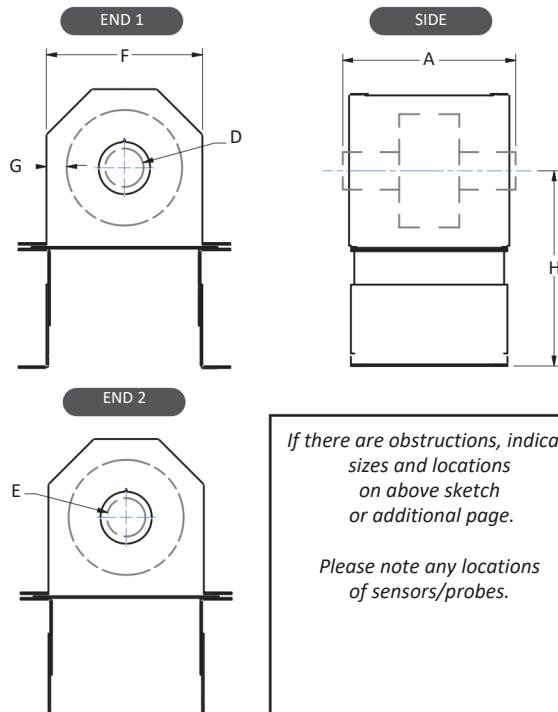

INFORMATION REQUIRED

ITEM	DIMENSION
A	Distance Between Motors/Gearboxes
B	Height From Floor/Base to Bottom of Coupling
C	Height From Floor/Base to Top of Coupling
D	Shaft Diameter (<i>End 1, Including keyway</i>)
E	Shaft Diameter (<i>End 2, Including keyway</i>)
F	Overall Width of Guard
G	Distance From Coupling to Guard
H	Height From Floor/Base to Centerline of Shaft

SPECIAL REQUIREMENTS

AREA	PLEASE INDICATE
Over-Heating Concerns	Yes/No
Corrosive Area	Yes/No
Fluid Coupling	Yes/No
Other	Yes/No

How would you like to attach the guard to base or floor?

Concrete Anchors
 Welded On
 J-bolts



EXAMPLES OF OBSTRUCTIONS THAT WE WOULD NEED TO KNOW ABOUT

ADDITIONAL NOTES / SKETCHES:



FLANGE BEARING GUARD DATA SHEET

COMPANY: _____
 CONTACT PERSON: _____
 LOCATION: _____
 PHONE: _____ FAX: _____
 EMAIL: _____
 EQUIPMENT #: _____

PLEASE SUBMIT PHOTOS WITH YOUR DATA SHEETS

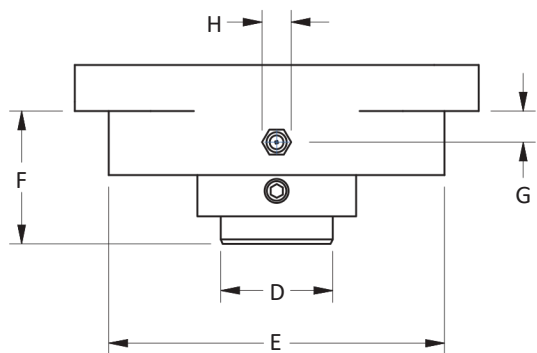

INFORMATION REQUIRED

ITEM	DIMENSION
A - Bolt Centers (<i>Square</i>)	
B - Bolt Centers (<i>Across</i>)	
C - Bolt Diameter	
D - Shaft Diameter	
E - Largest Case Diameter	
F - Mount Face to End of Shaft	
G - Distance to Nipple	
H - Diameter of Nipple	

OTHER DATA (IF KNOWN)

Bearing Type	
Manufacturer	
Model #	

SPECIAL REQUIREMENTS

AREA	PLEASE INDICATE
Lubrication	Yes/No
Vibration Analysis	Yes/No
Heat Analysis	Yes/No
Speed Sensing	Yes/No
Over-Heating Concerns	Yes/No
Corrosive Area	Yes/No
Flammable Area	Yes/No
Lead Paint Abatement Area	Yes/No
Other	

CIRCLE THE BOLT PATTERN REQUIRED

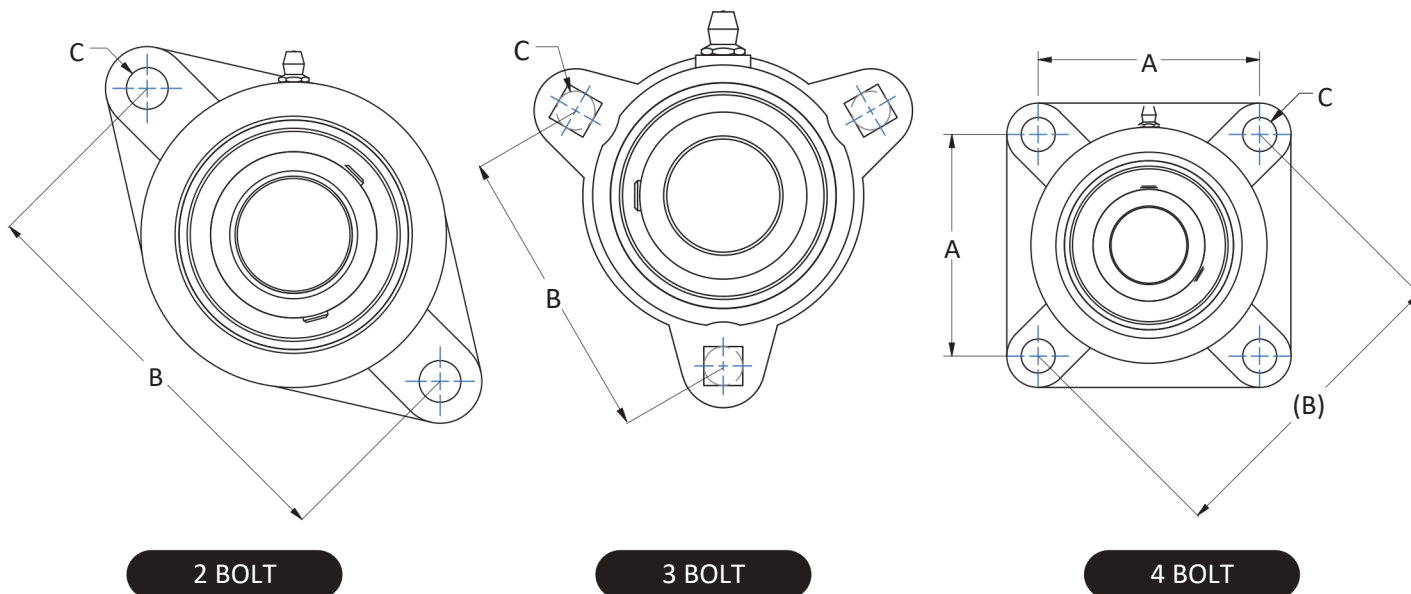

BOX GUARD DATA SHEET

COMPANY: _____
 CONTACT PERSON: _____
 LOCATION: _____
 PHONE: _____ FAX: _____
 EMAIL: _____
 EQUIPMENT #: _____

PLEASE SUBMIT PHOTOS WITH YOUR DATA SHEETS

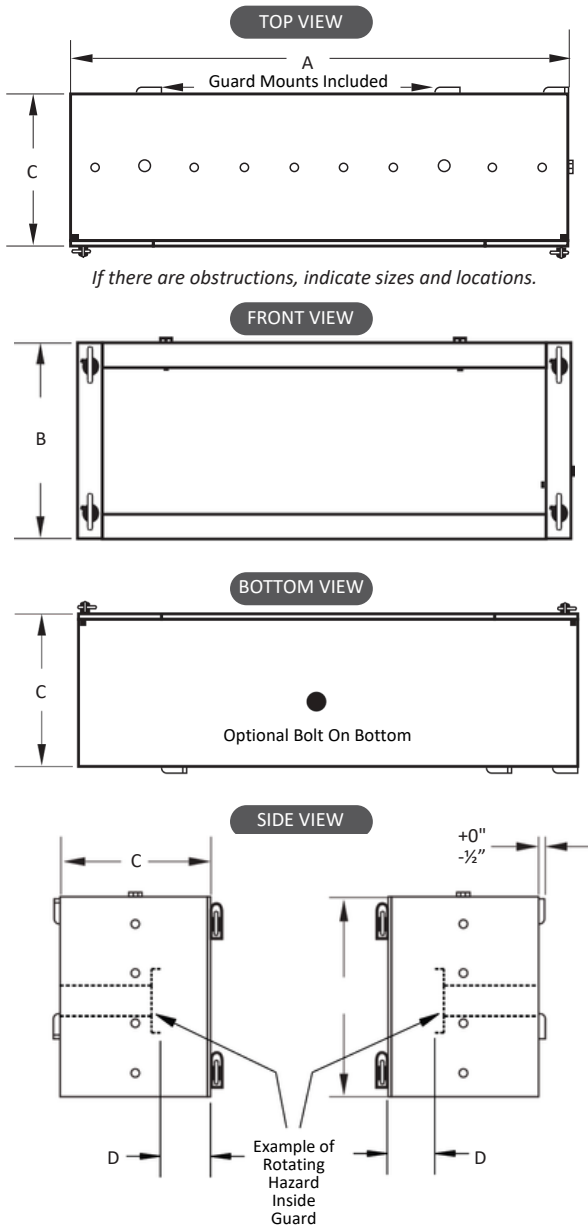

INFORMATION REQUIRED

ITEM	DIMENSION
A - Width of Box Guard	
B - Height of Box Guard	
C - Depth of Box Guard	
D - Distance from Guard Face to Hazard	
Do you require a bottom?	Yes/No
Do you require drainage slots in bottom?	Yes/No

SPECIFY GUARD COATING COLOR

ITEM	PLEASE INDICATE
Guard Body	Yellow/Black/Other
Guard Front Mesh Panel	Yellow/Black/Other

SPECIAL REQUIREMENTS

AREA	PLEASE INDICATE
Lubrication	Yes/No
Vibration Analysis	Yes/No
Heat Analysis	Yes/No
Speed Sensing	Yes/No
Over-Heating Concerns	Yes/No
Corrosive Area	Yes/No
Flammable Area	Yes/No
Lead Paint Abatement Area	Yes/No
Other	

ADDITIONAL NOTES / SKETCHES:



COMPANY: _____
LOCATION: _____
QUOTE LINE: _____
PIC#: _____ **TO:** _____
AREA: _____
EQUIPMENT #: _____
QUANTITY: _____

PLEASE SUBMIT PHOTOS WITH YOUR DATA SHEETS

INFORMATION REQUIRED

ITEM	DIMENSION
A - Width of Conveyor Frame	
B - Width From Center to Farthest Point (<i>Left Side</i>)	
C - Width From Center to Farthest Point (<i>Right Side</i>)	
D - Length From end to 36" Past Hazard	
E - Height to Lowest Rotating Hazard	
F - Height to Tallest Rotating Hazard	
G - Height to Center of Tail Pulley Shaft	
H - Height to Tracking Adjustment Bolts	
I - Width From Center to Tracking Adjustment Bolts	

GUARD HEIGHT

STANDARD 75" 81" Other: _____
 NON-STANDARD

SPECIAL REQUIREMENTS

AREA	PLEASE INDICATE
Pull Cable Eyes	Yes/No
Handles	Yes/No
Corrosive Environment	Yes/No
Black Mesh	Yes/No
Other	

How would you like to attach the guard to base or floor?

Concrete Anchors Welded On J-bolts

TOP VIEW OF TAIL SECTION

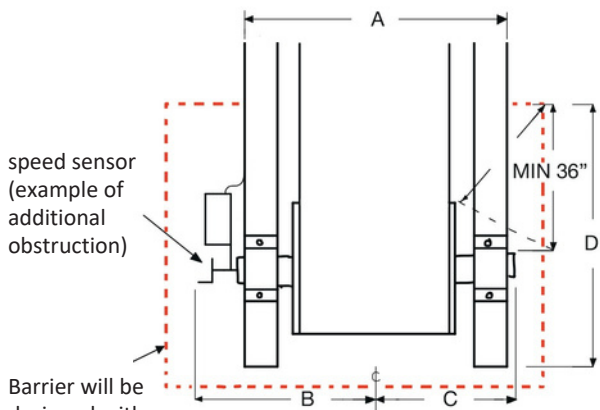

Barrier will be designed with 5" clearance around equipment and structure unless otherwise noted (Minimum 4")

END VIEW OF TAIL SECTION

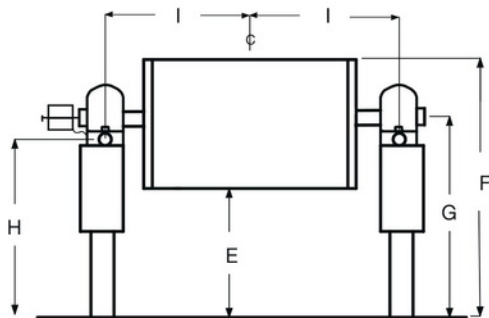

RIGHT VIEW OF TAIL SECTION

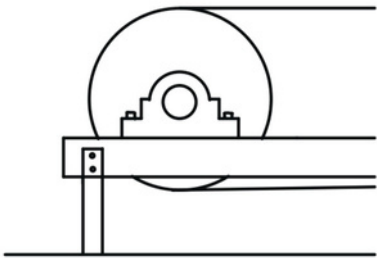

LEFT VIEW OF TAIL SECTION

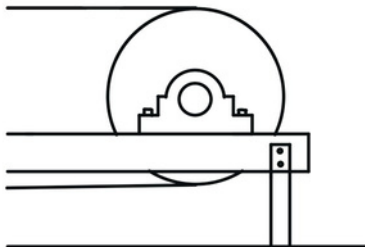

If there are obstructions, indicate sizes and locations on above sketch or additional page.

Please note any locations of sensors/probes.

PLEASE SUBMIT PHOTOS WITH YOUR DATA SHEETS.

**It is the responsibility of end user to ensure that all possible obstructions are accounted for and all measurements and dimensions are accurate.*



PARTS IDENTIFICATION

WITH EACH GUARDING SYSTEM, WE SUPPLY DRAWINGS THAT OUTLINE EACH COMPONENT OF THE SYSTEM AND CORRESPONDING IDENTIFICATION ON THE COMPONENTS.

- Removable guards are affixed with weight labels for safety during installation and maintenance
- Easy identification for future replacement parts
- Convenient for maintenance crews and technicians
- Efficient equipment referencing
- UV protected and water resistant
- Most components are labeled for ease of installation

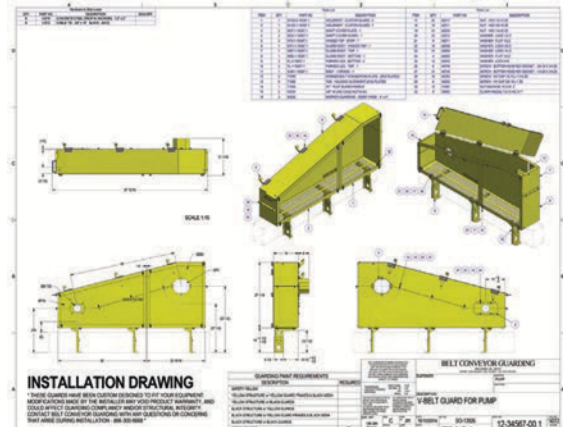

WEIGHT LABEL

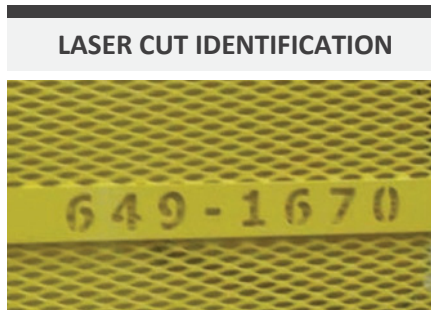

LASER CUT IDENTIFICATION



PART LABEL

ASSEMBLY AND INSTALLATION

Each guarding system is supplied with detailed installation drawings and instructions.

Technicians or Designers may be available for installation support via e-mail, voice or video call.

Note, our Technicians do not perform installations. Where on-site installation support is required, Technicians may be available to assist maintenance staff with on-site instruction.

We are continually improving the design and adjustability of our safety guarding to improve versatility and accommodate various conditions which may impact installation.

WHAT'S IN THE BOX OR ON THE SKID?

- Detailed Drawings & Efficient Equipment References
- Guard Parts & Installation Hardware
- Parts List & General Installation Instructions



COUPLING GUARD INSTALLATION INSTRUCTIONS

Required tools:
 ➤ 7/16", 5/16", and 3/4" wrench or ratchet and socket
 ➤ Carbide drill bit or router (depending on the base type)

Step 1. Shut down the machine to be guarded in accordance with on-site lock-out/tag-out procedures.

Step 2. Remove the existing guard (if applicable) and prepare the area for new installation.

Step 3. Open the wedge clamp on the new guard and remove the body parts from the leg assembly.

Step 4. Place the leg assembly centered within the two bearing cases and centered under the shaft.

Step 5. Adjust the legs so that the distance between the bottom of the coupling and the guards is about 1 1/2".

Step 6. Install the guard bodies. Note that the body flanges should not overlap.

Step 7. Adjust the guard height so the shaft is centered in the fill plates opening.

Step 8. Weld the tabs to the base or mark and drill, then use anchors to mount the guard to the base/floor.

Step 9. Extend the fill plates to close the space between the guard and the equipment.

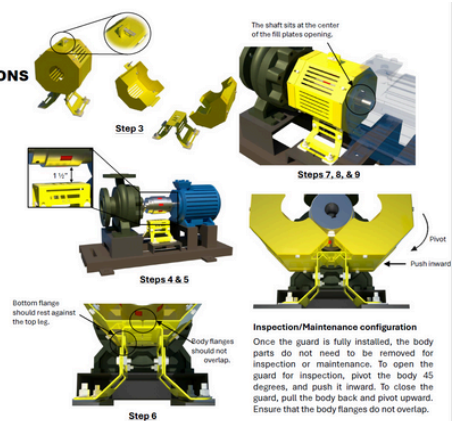

ARE YOUR SAFETY GUARDS COMPLIANT?

SERIOUS THOUGHT AND PLANNING CONTRIBUTES TO THE ERGONOMIC DESIGN OF A COMPLIANT SAFETY GUARDING SYSTEM. ACHIEVING EFFICIENT SOLUTIONS TO PROTECT YOUR WORKERS AND MAINTAIN COMPLIANCE SHOULD BE A TOP PRIORITY.

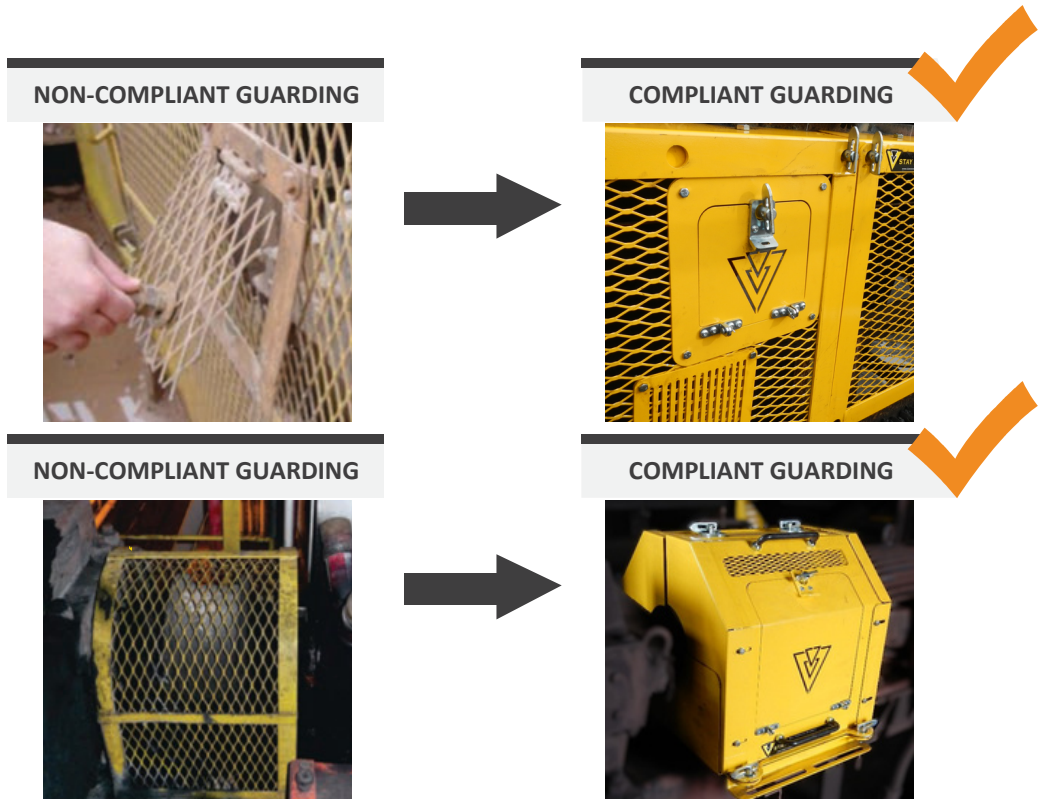

Although there are many detailed rules and regulations surrounding safety guarding compliance, it all starts with one basic question:

IS IT POSSIBLE TO REACH AROUND, UNDER, THROUGH OR OVER (AUTO) YOUR GUARDING AND CONTACT THE HAZARD?

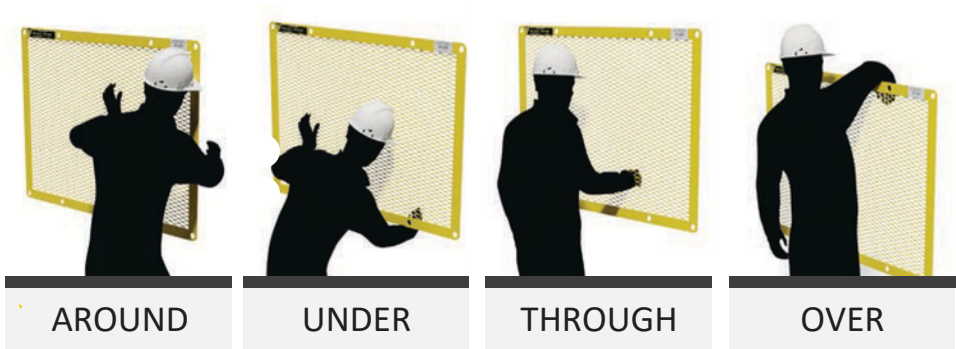

IF THE ANSWER IS **YES** - YOUR GUARDING IS NOT COMPLIANT. WE ARE HERE TO HELP YOU!

STAY AWAY - STAY SAFE



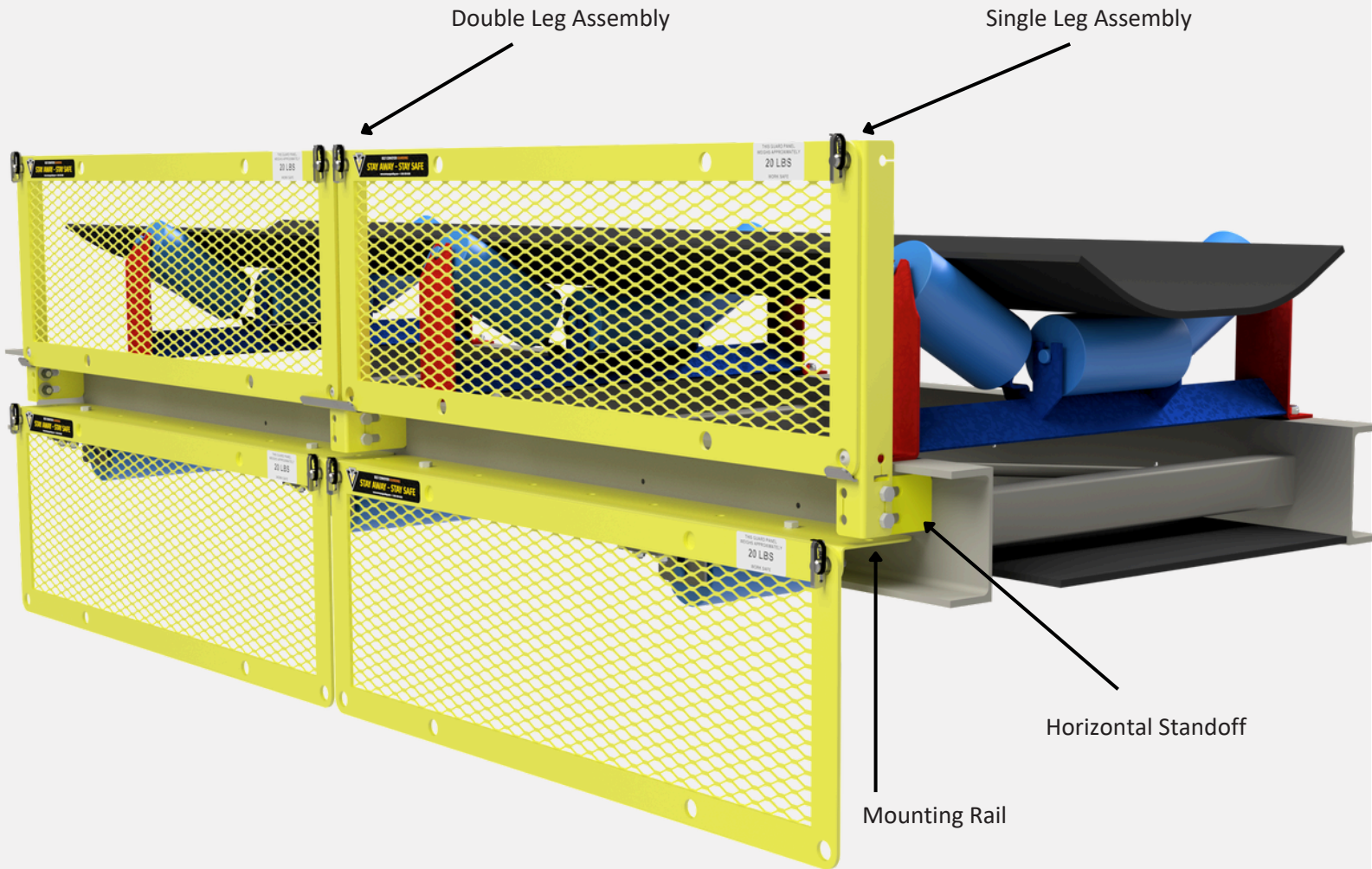

SAFETY GUARDING SOLUTIONS

GUARD IT RIGHT SAVE A LIFE



BELT CONVEYOR GUARDING
Proven Safety Guarding Solutions

1-866-300-6668 | safety@conveyorguarding.com
www.conveyorguarding.com